

PEARSON  
**Mathematics**  
STUDENT BOOK | VICTORIA

# 7

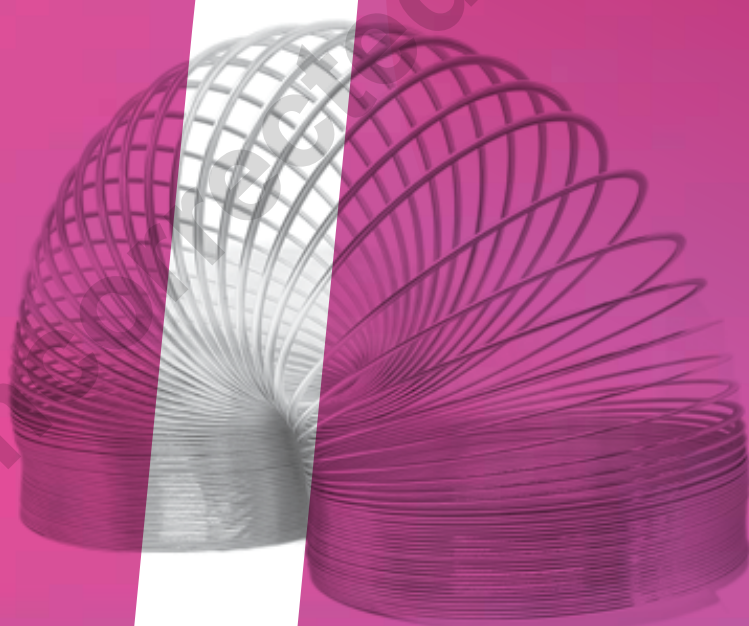

# Contents

<b>1</b>	<b>Number properties</b>	<b>1</b>	<b>4</b>	<b>Operations with fractions</b>	<b>91</b>
1.1	Understand and calculate squares and square roots	3	4.1	Understand how to add and subtract fractions	93
1.2	Understand and use exponent notation to represent numbers	9	4.2	Understand mixed numbers and improper fractions	97
1.3	Represent numbers in prime factor form	12	4.3	Find the fraction of an amount	101
1.4	Understand and identify common factors	19	4.4	Understand how to multiply fractions	105
1.5	Understand and use expanded notation to represent numbers	25	4.5	Understand how to divide fractions	108
<b>2</b>	<b>Operations with decimals</b>	<b>32</b>	<b>5</b>	<b>Modelling with fractions, decimals and percentages</b>	<b>118</b>
2.1	Round decimals for different purposes	34	5.1	Choose an appropriate representation to solve problems	120
2.2	Add and subtract decimals	41	5.2	Determine the proportion of a quantity	124
2.3	Multiply decimals	47	5.3	Understand percentage as applied to taxation	129
2.4	Divide decimals	52	5.4	Use fractions, decimals and percentages to solve financial problems	133
<b>3</b>	<b>Fractions, decimals and percentages</b>	<b>61</b>	5.5	Use, interpret and calculate discounts and mark-ups	137
3.1	Understand and create equivalent fractions	63	<b>6</b>	<b>Integers</b>	<b>147</b>
3.2	The lowest common denominator and comparing fractions	68	6.1	Understand integers and operations	149
3.3	Simplify fractions	71	6.2	Add and subtract integers	154
3.4	Understand the relationship between decimals, percentages and fractions	75	6.3	Model and solve practical problems using integers	161
3.5	Locate fractions and decimals on a number line	80	<b>7</b>	<b>Understanding ratios</b>	<b>173</b>
3.6	Compare fractions and decimals on a number line	83	7.1	Write ratios	175
			7.2	Understand equivalent ratios	180
			7.3	Understand the connection between fractions and ratios	185

# Contents

---

## **8 Algebra 193**

- 8.1 Understand variables in algebra 195
- 8.2 Identify and simplify like terms 199
- 8.3 Calculate the value of algebraic expressions 202
- 8.4 Write algebraic expressions in context 208

---

## **9 Linear relationships 215**

- 9.1 Understand the components of an equation and how they are combined 217
- 9.2 Generate a table of values using a linear equation 220
- 9.3 Recognise the connection between points on a Cartesian plane, a table of values and a linear pattern 229
- 9.4 Model linear patterns using manipulatives, diagrams and graphs 239

---

## **10 Making and reading linear graphs 250**

- 10.1 Graph linear relationships from a rule 252
- 10.2 Interpret the gradient of a linear graph 257
- 10.3 Interpret, discuss and analyse relationships in graphs 264

---

## **11 Solving linear equations 279**

- 11.1 Write linear equations to represent simple word problems 281
- 11.2 Write linear equations to represent diagrams and patterns 284
- 11.3 Use flow charts to determine the value of an expression 291
- 11.4 Use flow charts to solve linear equations 295
- 11.5 Use the balance method to solve linear equations 301

---

## **12 Area and volume 312**

- 12.1 Understand and convert between units of area 314
- 12.2 Calculate the area of a parallelogram 319
- 12.3 Calculate the area of a triangle 326
- 12.4 Understand volume measured in cubic units 336
- 12.5 Establish the volume formula and units for prisms 341
- 12.6 Explore the connection between volume and capacity 348

---

## **13 Circles (features and circumference) 361**

- 13.1 Recognise circle features 363
- 13.2 Understand how circumference is related to radius and diameter 370
- 13.3 Solve length problems involving circles 375

---

## **14 Angles and transversals 386**

- 14.1 Construct perpendicular and parallel lines 389
- 14.2 Identify corresponding, alternate and co-interior angles 393
- 14.3 Determine the exterior angle of a triangle 402
- 14.4 Calculate the internal angle sum of a triangle 406

---

## **15 Ratios and measurement 417**

- 15.1 Solve practical problems involving ratios of length 419
- 15.2 Explore ratios in measured quantities 427

# Contents

---

## **16 Visualising 3D 437**

- 16.1 Visualise and apply nets 439
- 16.2 Visualise and draw the perspective views of a 3D object 445
- 16.3 Draw and build objects made from cubes 450
- 16.4 Draw and use objects represented in art form 455

---

## **17 Triangles and quadrilaterals 465**

- 17.1 Construct triangles and quadrilaterals 467
- 17.2 Classify types of triangles by their side and angle properties 475
- 17.3 Classify types of quadrilaterals by their side and angle properties 484
- 17.4 Use parallel side lengths of quadrilaterals to construct rectangles of equivalent area 493

---

## **18 Translations, rotations, reflections 504**

- 18.1 Translate and reflect points and shapes on a Cartesian plane 506
- 18.2 Rotate shapes on a Cartesian plane 514

---

## **19 Data and measures of central tendency 536**

- 19.1 Understand different data types 538
- 19.2 Calculate the mean and range of a set of data 549
- 19.3 Calculate the mean and range for a set of grouped data 556
- 19.4 Determine the median of a data set 564
- 19.5 Determine an appropriate measure of central tendency 570

---

## **20 Displaying and understanding data 580**

- 20.1 Understand stem-and-leaf plots 582
- 20.2 Create and interpret statistical plots 588
- 20.3 Determine statistical measures of centre from data displays 596
- 20.4 Interpret and describe numerical data displays 607

---

## **21 Probability (simulations and sample space) 621**

- 21.1 List sample spaces and calculate the probability of single-step events 623
- 21.2 Record outcomes and run trials of chance experiments 632
- 21.3 Compare theoretical and experimental probability 641

COVER **Shutterstock**: ElenaChelysheva, dice; Flipser, speedometer; KateStudio, videogame accessories; Museum of illusions, slinky.

TOPIC

13

# Circles (features and circumference)

<b>Recall</b>	360
<b>13.1</b> Recognise circle features	361
<b>13.2</b> Understand how circumference is related to radius and diameter	368
<b>13.3</b> Solve length problems involving circles	373
<b>Topic review</b>	381

## Why learn this?

Learning about the features and circumference of circles enables students to:

- identify and understand the key features of a circle, such as the radius, diameter and circumference, and the relationships between them
- apply this understanding to a range of practical situations, such as measuring round objects, navigating circular paths or creating circular designs
- develop problem-solving skills by applying mathematical formulas to calculate the circumference of a circle given its radius or diameter, and vice versa
- understand the concept of pi and its role in calculating the circumference and area of circles
- use these skills in a variety of fields, including art, design, engineering and physics, where circles and circular motion are commonly encountered.

# RECALL

13

I can round decimals to the required place value

1 Write each of the following numbers to 2 decimal places.

(a) 67.3415

(b) 4.8196

(c) 2.2645

(d) 9.0073

(e) 4.308

I can perform calculations involving decimals

1 Calculate:

(a)  $2.6 \times 3.7$

(b)  $7.3 \times 0.7$

(c)  $7.03 \times 8.1$

(d)  $0.04 \times 6.2$

I can square integers and decimal numbers

1 Calculate:

(a)  $3^2$

(b)  $5^2$

(c)  $11^2$

(d)  $0.2^2$

(e)  $0.5^2$

(f)  $1.1^2$

I can convert between metric units of measurement

1 Complete the following unit conversions:

(a) 2.5 cm to mm

(b) 1.25 m to cm

(c) 305 mm to cm

(d) 25.5 cm to m

(e) 5.25 m to mm

I can calculate the perimeter of shapes

1 Calculate the perimeter of these shapes

(a)

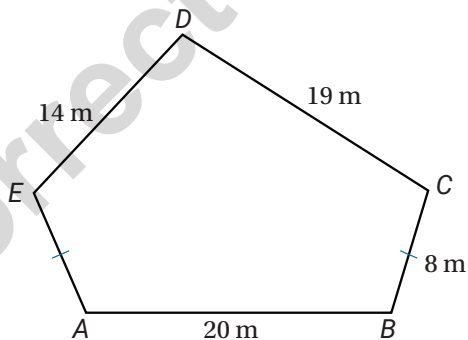

(b)

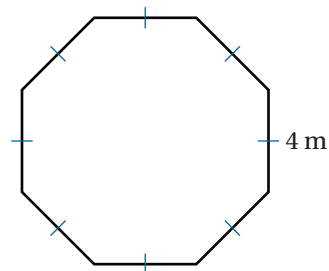

I can draw circles of any radius using a compass

1 Briefly describe how you would use a compass to draw a circle of:

(a) radius 4 cm

(b) diameter 12 cm.

# Recognise circle features

13.1

**Learning intention:** To be able to recognise circle features

**Success criteria:**

- SC 1** I can identify and define circles and their features.
- SC 2** I understand the relationship between the radius and diameter of a circle.

## Lesson warm-up

How does a compass draw a circle?

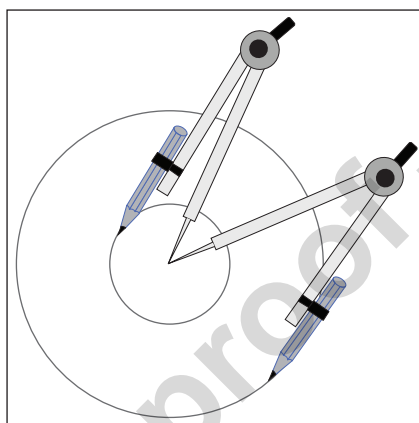

- 1 Write down how the compasses have been used to draw the circles.
- 2 Write down similarities and differences between the construction of the two circles.
- 3 List the features you need to name to accurately compare the circles.

**SC 1** I can identify and define circles and their features

A circle is a two-dimensional (flat) shape, with the property that every point on the circle is the same distance from the centre.

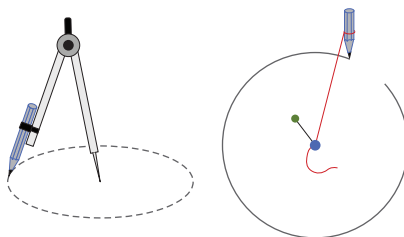

## Worked example

### Identifying circle features

Draw and label the following features of a circle: circumference, radius and diameter.

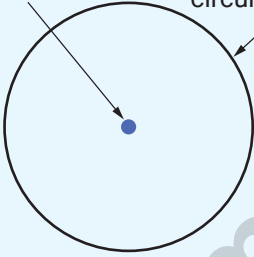
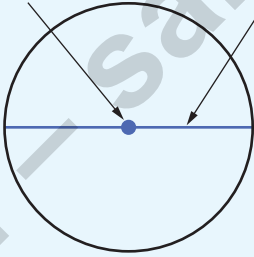
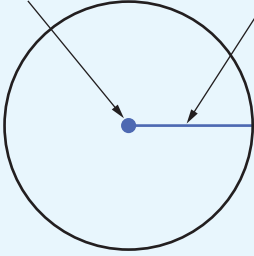
THINKING	WORKING
<p>Draw and label the circumference.</p> <p>The circumference is the perimeter of a circle.</p>	<p>centre      circumference</p> 
<p>Draw and label the diameter.</p> <p>A diameter of a circle is a line segment that touches two points on the circle, passing through the centre.</p> <p>A diameter divides a circle into two semicircles (half-circles).</p>	<p>centre      diameter</p> 
<p>Draw and label the radius.</p> <p>A radius is a straight line connecting the centre to any point on the circle.</p> <p>The plural of radius is radii.</p>	<p>centre      radius</p> 

**SC 2** I understand the relationship between the radius and diameter of a circle

The distance from the centre of a circle to the circumference is called the radius. The distance across a circle, through the centre, is the diameter.

By definition, every point on the circumference of a circle is the same distance from the centre. This means that every radius of a circle is the same length.

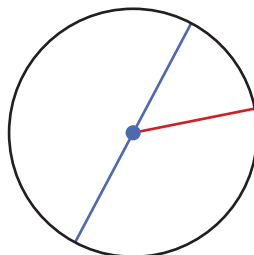

## Worked example

### Relating radius and diameter

- (a) Given that the radius is 12 cm, calculate the length of the diameter.

THINKING	WORKING
Determine the relationship between the diameter and radius. A radius is the length from the centre to the circumference. A diameter is the length joining two points on the circumference through the centre.	The length of the diameter is two times the length of the radius. $\text{Diameter} = 2 \times \text{radius}$
Substitute the length of the radius to calculate the length of the diameter.	$\text{Diameter} = 2 \times \text{radius}$ $= 2 \times 12 \text{ cm}$ $= 24 \text{ cm}$
Interpret the answer.	A circle with a radius of 12 cm has a diameter of 24 cm.

- (b) Given that the diameter is 12 cm, calculate the length of the radius.

THINKING	WORKING
Determine the relationship between the diameter and the radius. A radius is the length from the centre to the circumference. A diameter is the length joining two points on the circumference through the centre.	The length of the radius is half the length of the diameter. $\text{radius} = \frac{1}{2} \text{ diameter}$
Substitute the length of the diameter to calculate the length of the radius.	$\text{radius} = \frac{1}{2} \times \text{diameter}$ $= \frac{1}{2} \times 12 \text{ cm}$ $= 6 \text{ cm}$
Interpret the answer.	A circle with a diameter of 12 cm has a radius of 6 cm.

**SC 1** I can identify and define circles and their features

1 Name and define the feature highlighted blue in each circle.

(a)

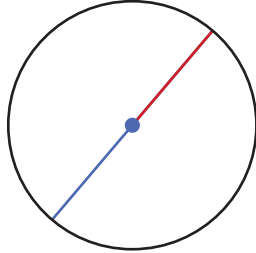

(b)

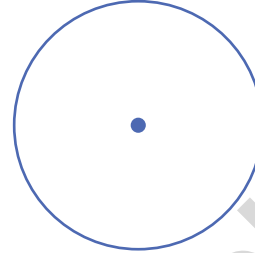

(c)

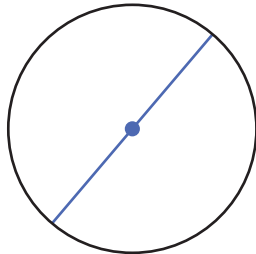

(d)

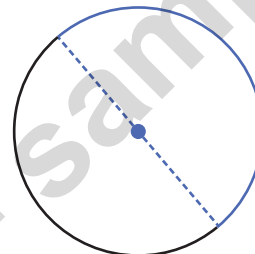

2 Draw and label the following circle features.

(a) A diameter

(b) A radius

(c) A semicircle

3 A circle is drawn inside a square, with the sides just touching. Name the feature of the circle that is the same length as the square's side length.

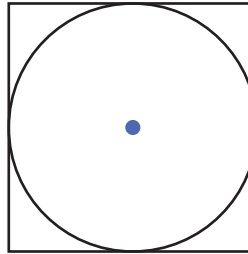

4 Is it possible to draw a straight line segment connecting two points on a circle that is:

(a) shorter than the radius

(b) longer than the diameter?

Explain each answer using a diagram.

- 5 Overlapping circles can be used to draw flower-like patterns such as the following.

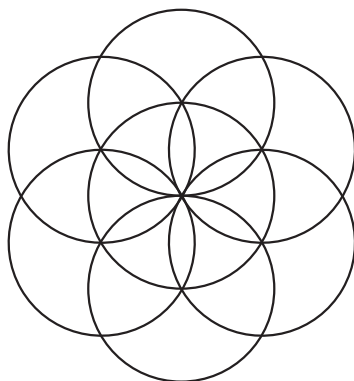

- (a) When only one circle is drawn, there is no visible centre point. Explain how you could locate the centre using paper folding.
- (b) Describe how to place the circle template to draw a second circle.
- (c) Describe how to place the third circle.
- (d) Explain why there are six outer circles.

**SC 2** I understand the relationship between the radius and diameter of a circle

- 1 Given the length of the diameter, determine the length of the radius for each circle.

(a)

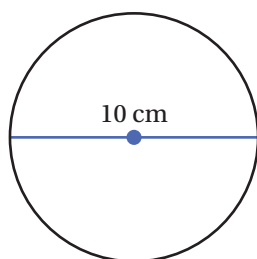

(b)

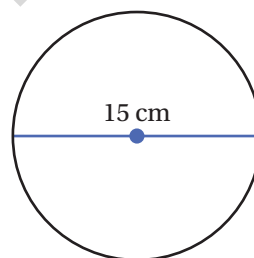

(c)

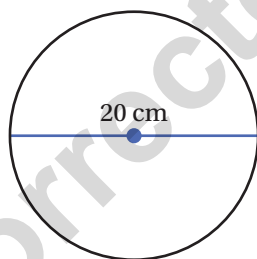

(d)

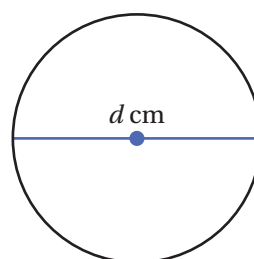

- (e) Given the length of the diameter, describe how to calculate the length of the radius.

- 2 Given the length of the radius, determine the length of the diameter for each circle.

(a)

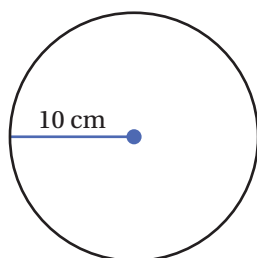

(b)

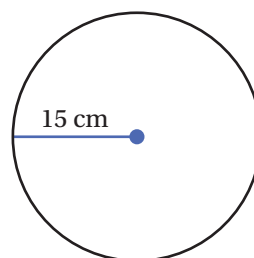

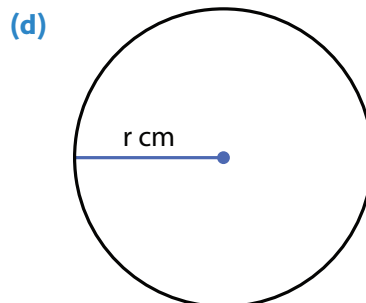
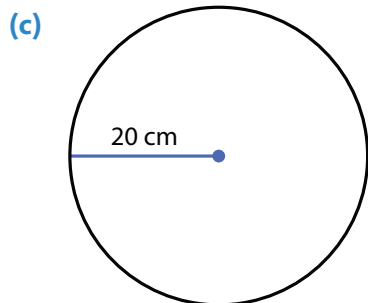

(e) Given the length of the radius, describe how to calculate the length of the diameter.

- 3 A compass setting is changed to draw a circle with a radius three times larger than the radius of the smaller circle. Two students describe how they think the diameter will change. Which student is correct? Explain.

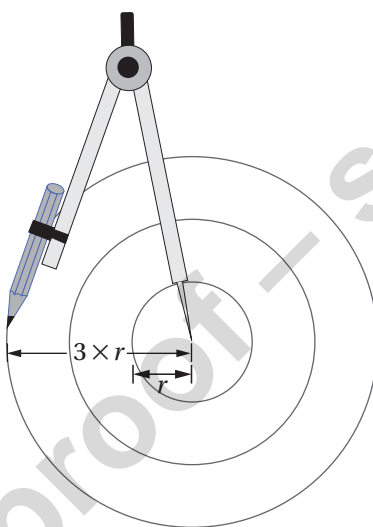

Student A	Student B
The diameter of the bigger circle will be three times as long as the diameter of the smaller circle.	The diameter of the bigger circle will be six times as long as the diameter of the smaller circle.

- 4 A compass setting is changed to draw a circle with a radius 3 cm longer than the radius of the smaller circle. Two students describe how they think the diameter will change.

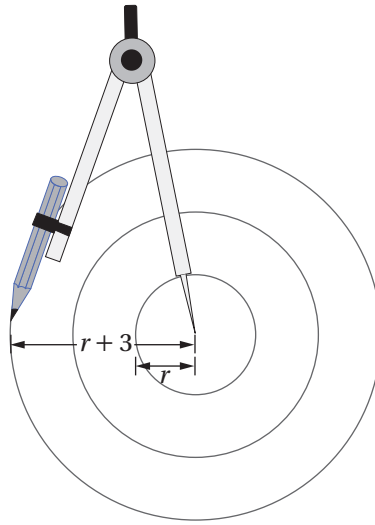

Student A	Student B
The diameter of the bigger circle will be 3 cm longer than the diameter of the smaller circle.	The diameter of the bigger circle will be 6 cm longer than the diameter of the smaller circle.

Which student is correct? Explain.

- 5 Three semicircles are connected so that the width of the shape is 20 cm as shown.

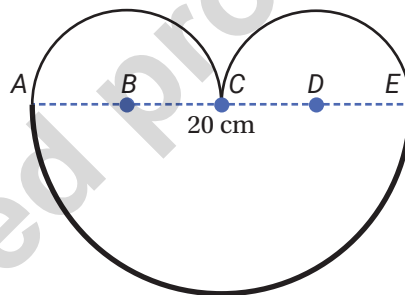

- Determine the length of the diameter of the large semicircle,  $AE$ .
  - Label and determine the length of the radius of the large semicircle.
  - Label and determine the length of the diameter of the small semicircles.
  - Label and determine the length of the radii of the small semicircles.
- 6 A hexagon is drawn within a circle as shown.

Use the letter labels of each point to name the line segments shown.

- Name each line segment that is a radius.
- Name each line segment that is a diameter.

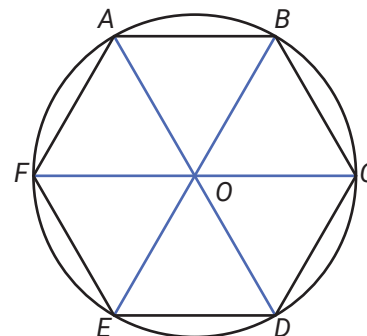

# 13.2

## Understand how circumference is related to radius and diameter

**Learning intention:** To understand how circumference is related to radius and diameter

**Success criteria:**

**SC 1** I understand the relationship between the circumference, the radius and the diameter.

**SC 2** I can approximate the value of pi.

13

### Lesson warm-up

#### Circles: when and how are they measured?

What are some examples of circumferences that we measure? What is the most practical way to measure or estimate the circumference of circles? Discuss.



#### What kind of measures can be used to work out how big a circle is?

What are some examples of circumferences that we measure? What is the most practical way to measure or estimate the circumference of circles? Discuss.

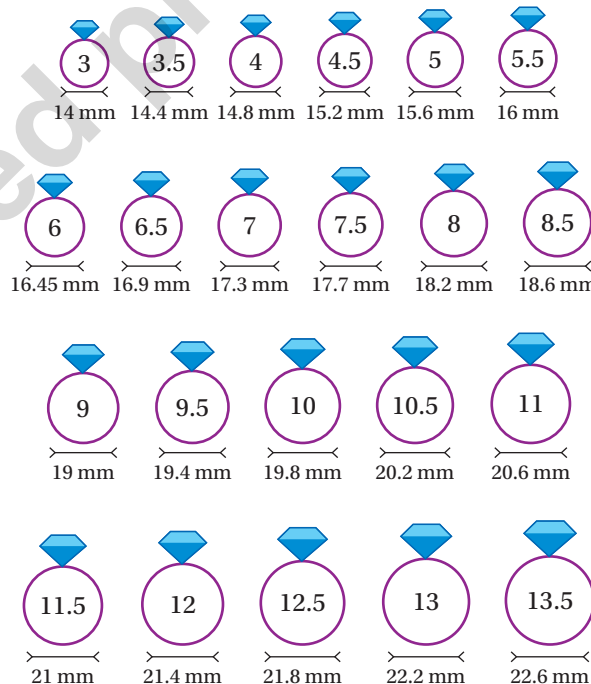

**SC 1** I understand the relationship between the circumference, the radius and the diameter

The perimeter of a circle is called the circumference.

The distance from the centre to the circumference is called the radius.

A diameter of a circle is a straight line segment connecting two points on the circle and passing through the centre.

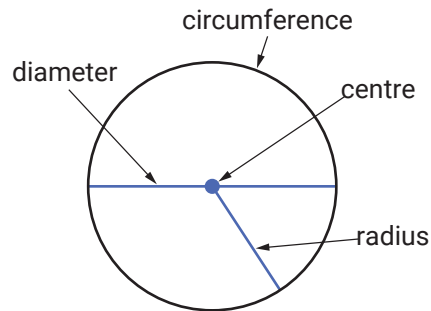

**Worked example**

**Comparing lengths of circumference, radius and diameter**

A circle has a radius of 6 mm.

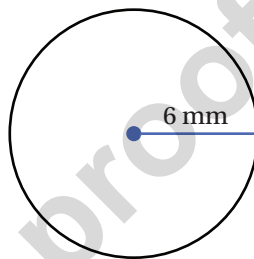

(a) Calculate the length of the diameter.

THINKING	WORKING
Draw the diameter. The diameter is a straight line segment connecting two points on a circle and passing through the centre.	<p>A diagram of a circle with a central blue dot. A horizontal red line segment passes through the centre from one side of the circle to the other, labeled '6 mm'.</p>
Calculate the length of the diameter as two times the radius length.	$2 \times 6 = 12$ The diameter is 12 mm.

- (b) Estimate the length of the circumference, given that it is known to be between 3 and 4 times the length of the diameter.

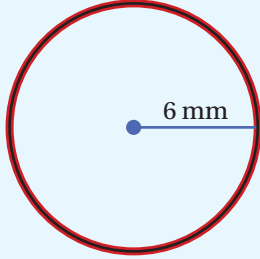
THINKING	WORKING
Draw the circumference. The circumference is the perimeter of the circle.	
Calculate the estimations for the circumference.	The diameter of the circle is 12 mm. The circumference is longer than $3 \times 12 = 36$ mm and shorter than $4 \times 12 = 48$ mm
Interpret the answer.	The circumference of the circle is between 36 mm and 48 mm.

**SC 2** I can approximate the value of pi

The exact value of the ratio of a circle's circumference to its diameter  $\frac{C}{d}$  (where  $C$  is circumference and  $d$  is diameter) is given the Greek letter pi ( $\pi$ ):  $\frac{C}{d} = \pi$ .

**Worked example**

**Approximating the value of  $\pi$**

Calculate an approximate value for  $\pi$ , to 2 decimal places, given the measurements: radius 14.32 cm, circumference 90 cm.

THINKING	WORKING
Write the given measurements using symbols.	$r = 14.32$ cm, $C = 90$ cm
Calculate the diameter from the radius.	$d = 2r$ $= 2 \times 14.32$ $= 28.64$
Substitute values into the formula for $\pi$ . Use the 'approximately equals' symbol $\approx$ to show that the measured values are approximate.	$\pi = \frac{C}{d}$ $\approx \frac{90}{28.64}$ $\approx 3.142\dots$
Round the result to 2 decimal places.	$\pi = 3.14$ (2 d.p.)

**SC 1** I understand the relationship between the circumference, the radius and the diameter

- 1 Draw a circle with each of the radii below. Measure the circumference of each circle to the nearest millimetre.
- (a) 2 cm                      (b) 3 cm                      (c) 4 cm                      (d) 6 cm
- (e) Explain what happens to the length of the circumference when the length of the radius doubles.
- (f) Explain what happens to the length of the circumference when the length of the radius is increased by 1 unit.
- 2 Use your answers from Question 1 to:
- (a) copy and complete the table.

Radius	Diameter	Circumference	$\frac{C}{d}$	$\frac{C}{r}$
2 cm				
3 cm				
4 cm				
6 cm				

- (b) complete the statements:
- (i) The circumference is about \_\_\_\_\_ times as long as the diameter.
- (ii) The circumference is about \_\_\_\_\_ times as long as the radius.
- 3 A circle fits exactly inside a square as shown.
- A regular hexagon is made of six equilateral triangles. If the hexagon is inside a circle (as shown), then the hexagon sides are each the same length as the circle radius.
- (a) Describe the side length of the square in terms of the radius of the circle.
- (b) Describe the side length of the hexagon in terms the radius of the circle.
- (c) Use your answers to parts (a) and (b) to determine the perimeter of each of the shapes and list them in order from longest to shortest.
- 4 Estimate the length of the circumference of the following circles and explain your answer.
- (a) The length of the radius is 6 m.                      (b) The length of the radius 6.5 m.
- (c) The length of the diameter is 6 m.                      (d) The length of the diameter is 6.5 m.
- 5 Estimate the length of the diameter of the following circles and explain your answer.
- (a) Circumference of 30 cm                      (b) Circumference of 35 cm                      (c) Circumference of 35.5 cm

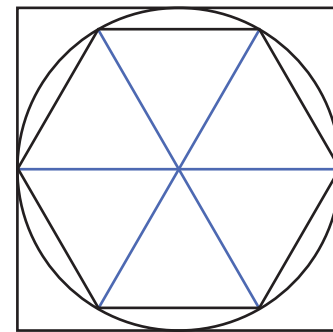

**SC 2** I can approximate the value of pi

1  $\pi \approx 3.141\ 592\ 654\dots$

Write the value of  $\pi$  correct to the following number of decimal places:

- (a) 1 decimal place (b) 8 decimal places.

2 Determine an approximation for  $\pi \approx 3.141\ 592\ 654\dots$  using  $\frac{C}{d}$ , given the following circle measurements.

- (a) Diameter 12 mm, circumference 38 mm  
 (b) Diameter 12.1 mm, circumference 38.1 mm  
 (c) Diameter 12.136, circumference 38.126  
 (d) What happens to the ratio  $\frac{C}{d}$  as the accuracy of the measurements of  $C$  and  $d$  increases?

3 Describe the relationship between the radius and diameter of a circle.

4 Determine an approximation for  $\pi \approx 3.141\ 592\ 654\dots$  using  $\frac{C}{d}$ , given the following circle measurements.

- (a) Radius 2.5 m, circumference 16 m  
 (b) Radius 2.55 m, circumference 16.02 m  
 (c) Radius 2.549 m, circumference 16.016 m  
 (d) What happens to the ratio  $\frac{C}{d}$  as the accuracy of the measurements  $C$  and  $r$  increases?

5 Before scientific calculators, people often used the fraction  $\frac{22}{7}$  as a convenient approximation for  $\pi$ .

- (a) Compare the calculations for the following circles and write each answer correct to six significant figures (in this case, six digits).

Diameter	$C = \pi \times d$	$C = \frac{22}{7} \times d$
1 m		
10 m		
100 m		
1000 m		
10 000 m		

- (b) Compare the calculations. Do you think the fraction  $C = \frac{22}{7}$  is a good approximation for  $\pi$ ? Explain.

# Solve length problems involving circles

13.3

**Learning intention:** To be able to solve length problems involving circles

**Success criteria:**

- SC 1** I can calculate circumference given the radius or diameter.
- SC 2** I can determine the length of a radius and diameter from a circumference.
- SC 3** I can calculate the perimeter of shapes involving circles.

## Lesson warm-up

**What is a yarning circle and how much space do you need to create one?**

A yarning circle is an important part of Aboriginal and Torres Strait Islander culture. It is used to learn, to build respectful relationships and to ensure that cultural knowledge is preserved.

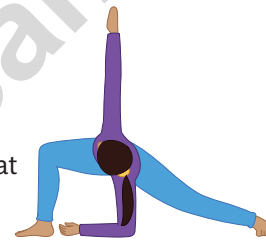

## How to participate in a yarning circle

- 1 Everyone sits in a circle with their legs crossed.
- 2 Everyone introduces themselves.
- 3 The host introduces the purpose of the yarning circle with a focus question.
- 4 Participants take turns to share ideas.
- 5 Participants take time to reflect.

## Task

With the students in your class, what is the diameter of space you would need to create a yarning circle?

13

**SC 1** I can calculate circumference given the radius or diameter

For every circle:  $\frac{\text{circumference}}{\text{diameter}} = \frac{C}{d} = \pi$ , where  $\pi = 3.141\ 59\dots$

This means the length of the circumference can be calculated if the diameter or radius is known, using the formula:  $C = \pi d$  or  $C = 2\pi r$ .

**Worked example**

**Calculating circumference**

- (a) Calculate the circumference, correct to 2 decimal places.

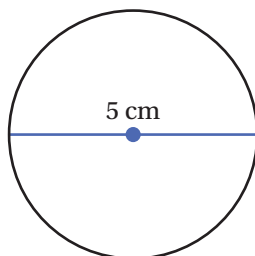

THINKING	WORKING
Write the given information using variables.	Diameter: $d = 5$ cm
Choose the circumference formula that includes the given information (diameter or radius).	Circumference: $C = \pi d$
Substitute the values into the formula and calculate the result.	$C = \pi \times 5$ $= 15.707\dots$
Round the result to the required number of decimal places.	$C = 15.71$ cm (2 d.p.)
Interpret the answer.	A circle with a diameter of 5 cm has a circumference of 15.71 cm.

- (b) Using the radius, calculate the circumference of the same circle, correct to two decimal places.

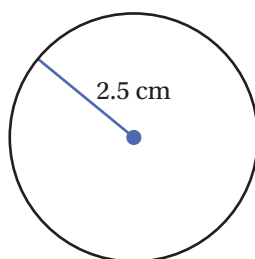

THINKING	WORKING
Write the given information using variables.	Radius: $r = 2.5$ cm
Choose the circumference formula that includes the given information (diameter or radius).	Circumference: $C = 2\pi r$
Substitute the values into the formula and calculate the result.	$C = 2 \times \pi \times 2.5$ $= 15.707\dots$
Round the result to the required number of decimal places.	$C = 15.71$ cm (2 d.p.)
Interpret the answer.	A circle with a radius of 2.5 cm has a circumference of 15.71 cm.

**SC 2** I can determine the length of a radius and diameter from a circumference

Given that the relationship between the circumference and diameter is known to be:

$$\frac{\text{circumference}}{\text{diameter}} = \frac{C}{d} = \pi, \text{ where } \pi = 3.141\ 59\dots$$

then given the circumference, the radius and diameter can be determined by changing the subject of the formulas:

$$C = \pi d \quad \text{or} \quad C = 2\pi r$$

$$d = \frac{C}{\pi} \quad \text{or} \quad r = \frac{C}{2\pi}$$

## Worked example

### Given the circumference, determine the length of the radius and diameter

- (a) Determine the length of the diameter, correct to 2 decimal places, of the circle with a circumference of 22 mm.

THINKING	WORKING
Write the given information using variables.	Circumference: $C = 22$ mm
Choose the circumference formula that includes the given information (diameter or radius).	Circumference: $C = \pi d$
Substitute the values into the formula and calculate the result.	$22 = \pi \times d$ $d = \frac{22}{\pi}$ $= 7.0028\dots$
Round the result to the required number of decimal places.	$d = 7.00$ mm (2 d.p.)
Interpret the answer.	A circle with a circumference of 22 mm has a diameter of 7.00 mm.

- (b) Calculate the length of the radius, correct to 2 decimal places, of the circle with a circumference of 22 mm.

THINKING	WORKING
Write the given information using variables.	Circumference: $C = 22$ mm
Choose the circumference formula that includes the given information (diameter or radius).	Circumference: $C = 2\pi r$
Substitute the values into the formula and calculate the result.	$22 = 2 \times \pi \times r$ $r = \frac{22}{2\pi}$ $= 3.501\dots$
Round the result to the required number of decimal places.	$r = 3.50$ mm (2 d.p.)
Interpret the answer.	A circle with a circumference of 22 mm has a radius of 3.50 mm.

**SC 3** I can calculate the perimeter of shapes involving circles

The perimeter is the distance around a shape.

**Worked example**

**Calculating the perimeter of shapes involving circles**

Determine the perimeter of this shape, correct to 2 decimal places.

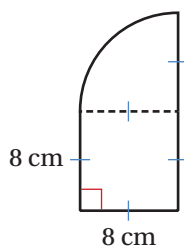

THINKING	WORKING
Identify the sections of the perimeter.	There are three sides of a square, each is 8 cm. One circle radius that is 8 cm. One quarter of a circumference.
Write an equation to determine the length of the curved edge.	Quarter of the circumference of circle: $\frac{1}{4} \times C = \frac{1}{4} \times 2\pi r$ radius, $r = 8$ cm
Write the perimeter formula for the complete shape.	$P = 3 \text{ sides of square} + \text{radius} + \text{quarter circle}$ $= (8 + 8 + 8) + 8 + \left(\frac{1}{4} \times 2\pi r\right)$
Substitute the values into the formula and calculate the result.	$P = (8 + 8 + 8) + 8 + \left(\frac{1}{4} \times 2 \times \pi \times 8\right)$ $= 24 + 8 + 12.5663\dots$ $= 44.5663\dots$
Round the result to the required number of decimal places.	$P = 44.57$ cm (2 d.p.)
Interpret the answer.	The perimeter of the shape, correct to 2 decimal places is 44.57 cm.

**SC 1** I can calculate circumference given the radius or diameter

1 Calculate the circumference of each circle, correct to 2 decimal places.

(a)

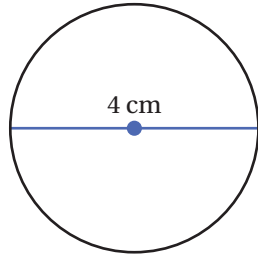

(b)

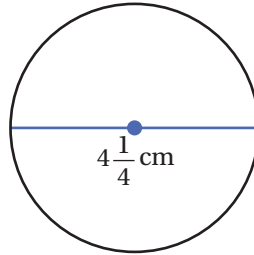

(c)

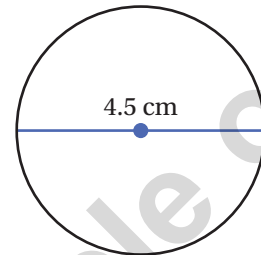

2 Calculate the circumference of each circle, correct to 2 decimal places.

(a)

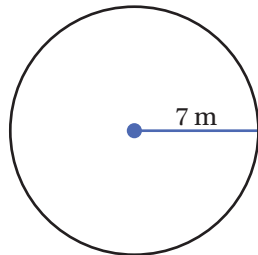

(b)

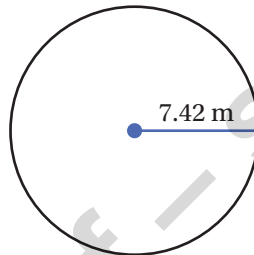

(c)

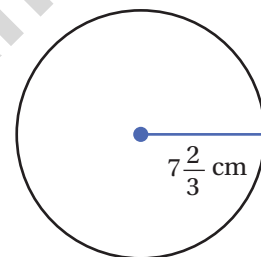

3 Calculate the diameter  $d$  and circumference  $C$  of each circle, correct to 2 decimal places, given the following radii.

(a)  $r = 25$  mm(b)  $r = 30$  mm(c)  $r = 35$  mm

4 Calculate the radius  $r$  and circumference  $C$  of each circle, correct to 2 decimal places, given the following diameters.

(a)  $d = 15$  m(b)  $d = 18$  m(c)  $d = 21$  m

5 When calculating the circumference, do you have a preferred method or strategy? Explain.

**SC 2** I can determine the length of a radius and diameter from a circumference

1 For circles with the following circumferences, use the formula  $C = \pi d$  to:

(a) determine the length of the diameter  $d$ (b) then halve part (a) to determine the length of the radius  $r$ .

Round your answers to 2 decimal places.

(i) 2.5 cm

(ii) 25 cm

(iii) 250 cm

2 For circles with the following circumferences, use the formula  $C = 2\pi r$  to:

(a) determine the length of the radius  $r$ (b) then double part (a) to determine the length of the diameter  $d$  of the same circle.

Round your answers to 2 decimal places.

(i) 2.5 cm

(ii) 25 cm

(iii) 250 cm

- 3 Given a circumference, explain when you might use each of the formulas  $C = 2\pi r$  and  $C = \pi d$ .
- 4 Given the following circumferences, calculate the diameter of each circle, correct to 2 decimal places.
- (a) 25 mm                      (b) 30 mm                      (c) 35 mm
- 5 Given the following circumferences, calculate the radius of each circle, correct to 2 decimal places.
- (a) 15 m                      (b) 18 m                      (c) 21 m

**SC 3** I can calculate the perimeter of shapes involving circles

- 1 Calculate the perimeter of each shape, correct to 2 decimal places. Each curved side is part of a circle.

(a)

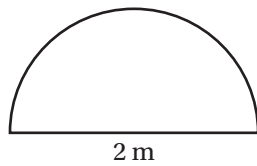

(b)

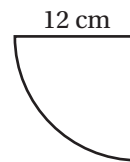

- 2 Calculate the perimeter of this shape, correct to 2 decimal places. Each curved side is part of a different circle.

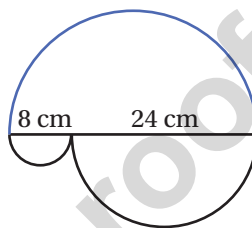

- 3 Calculate the perimeter of each shape, correct to 2 decimal places. Each curved side is part of a circle.

(a)

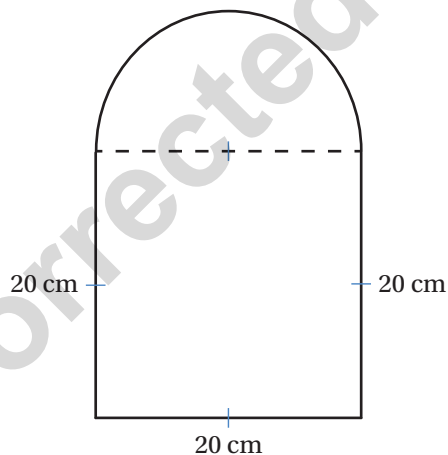

(b)

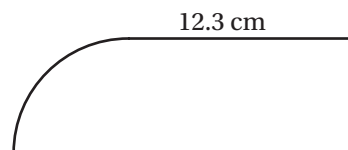

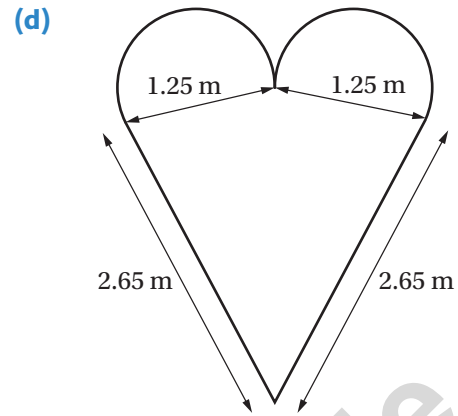
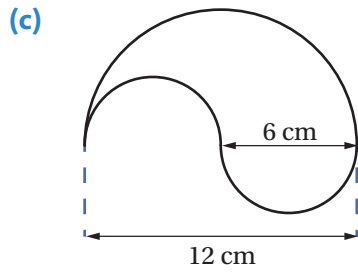

- 4 Calculate the perimeter of each shape, correct to 2 decimal places. Each curved side is part of a circle.

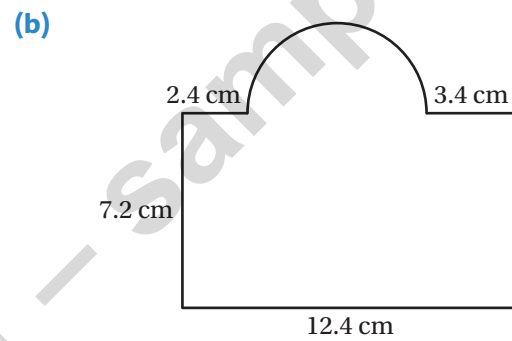
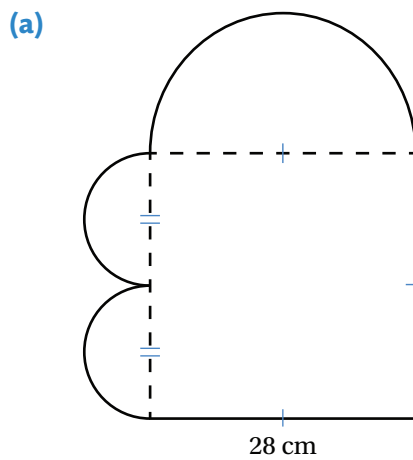

- 5 A rectangle measuring 128 mm by 82 mm has quarter circles of radius 30 mm cut from each corner. Determine the perimeter of the resulting shape, correct to the nearest millimetre.

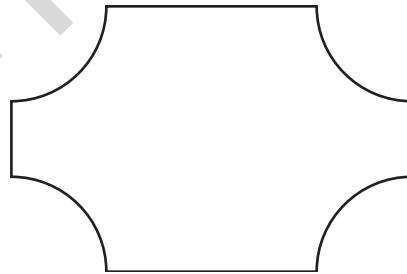

- 6 A jigsaw puzzle piece is shaped like a square with identical semicircles added or removed at each side, as shown. Determine its perimeter, correct to 1 decimal place (in centimetres).

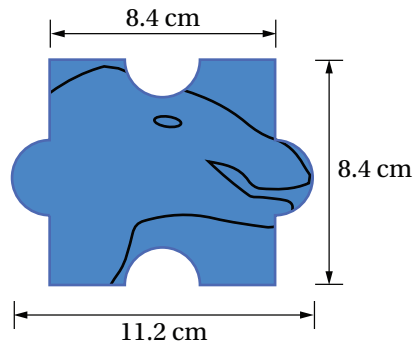

# TOPIC REVIEW

ANSWERS Page XXX

## Multiple choice

- Which of the following representations of pi, the ratio between circumference and diameter, is incorrectly rounded?  
**A** 3.14                      **B** 3.141                      **C** 3.1416                      **D** 3.1
- The lengths of diameter, radius and circumference are very roughly in the ratio:  
**A** 1 : 2 : 3                      **B** 1 : 2 : 6                      **C** 2 : 1 : 3                      **D** 2 : 1 : 6
- A circle of diameter  $20\frac{1}{8}$  cm has a circumference, correct to 2 decimal places, of:  
**A** 63.22 cm                      **B** 126.44 cm                      **C** 63.23 cm                      **D** 126.45 cm
- A circle of radius 16 cm has a circumference, correct to 2 decimal places, of:  
**A** 100.54 cm                      **B** 50.27 cm                      **C** 100.53 cm                      **D** 50.26 cm
- A semicircle of radius 10.5 cm has a perimeter, correct to 2 decimal places, of:  
**A** 53.99 cm                      **B** 32.99 cm                      **C** 107.97 cm                      **D** 65.98 cm

## Short answer

- Draw a circle showing two chords, one shorter than the radius and one longer than the radius.
- The two small semicircles attached to the rectangle are the same size.

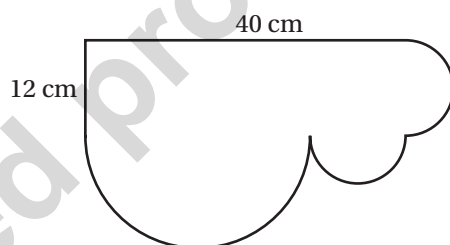

- Determine the lengths of the diameters of the three semicircles.
  - Determine the lengths of the radii of the three semicircles.
- Use a pair of compasses to draw a circle of radius 7.2 cm.
    - What is the length of the diameter?
    - Use a strip of paper to determine the length of the circumference to the nearest millimetre.
    - Determine the values of the ratios  $\frac{C}{d}$  and  $\frac{C}{r}$  correct to 2 decimal places.
  - The circumference of a circle is 30 cm. Complete the statement by choosing one of each alternative in each case. The radius of the circle will a bit be more/less than 5 cm /10 cm /60 cm.
  - The circumference of a circle is 85 cm. Determine the length of the radius to the nearest centimetre.

- 6 Approximate a value for  $\pi$ , correct to 2 decimal places, given:
- (a) radius of 2.4 m, circumference of 15.1 m
  - (b) diameter of 37 cm, circumference of 1.2 m.
- 7 Use  $\pi \approx \frac{22}{7}$  to calculate the circumference, given:
- (a) diameter of 35 m
  - (b) radius of 77 cm.
- 8 Calculate the perimeter of the shape, correct to 2 decimal places.

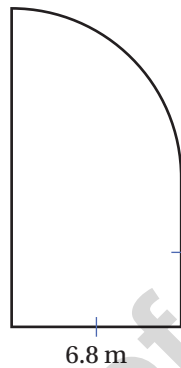

- 9 Use  $\pi \approx \frac{22}{7}$  to calculate the perimeter of the shape.

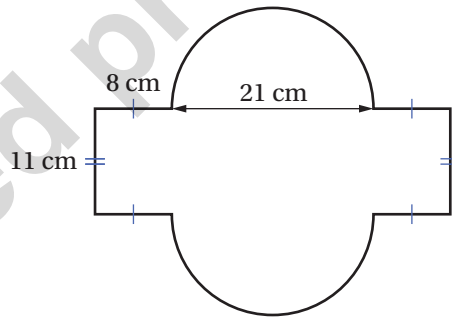

- 10** A loop of string forms an equilateral triangle of side length 84 cm. The string is then used to form the shape of a semicircle on a rectangle.

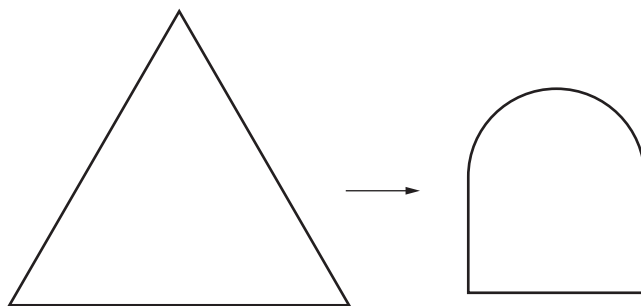

- (a) Determine the length of the other two sides, correct to the nearest millimetre, given the base is 50 cm.
- (b) Use guess and check to determine the length of the base of the shape, to the nearest centimetre, given the two vertical sides are 50 cm.

### Extended response

- 1** The middle section of the running tracks for athletics training are in the shape of a rectangle 60 m by 50 m, with semicircles on either end. Each lane is 1.25 m wide. The distance travelled in each lane assumes the runner hugs the inner line marking. Round answers to the nearest centimetre.

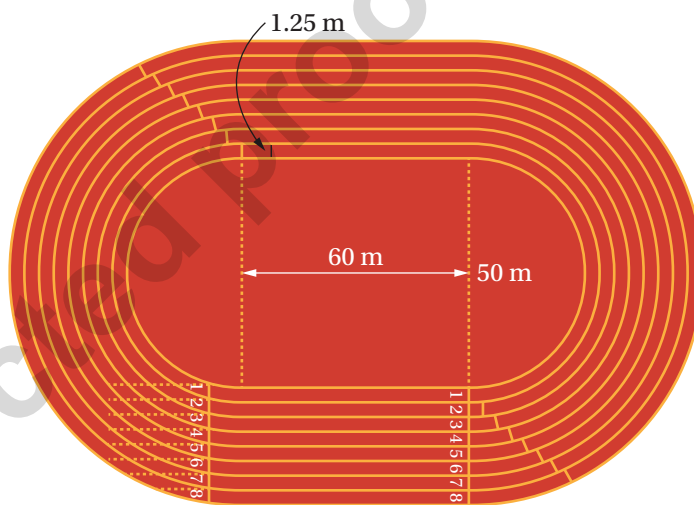

- (a) Determine the distance travelled over one lap in Lane 1.
- (b) How much further does a person travel for each lap in Lane 2?
- (c) What distance does a person in Lane 8 cover in 10 laps?

# Pearson Secondary Teaching Hub – Teaching program

## Victorian Curriculum v2.0

### Level 7

Pearson Secondary Teaching Hub mathematics lessons provide a systematic approach to deliver content in manageable chunks of content, defined by and written specifically to success criteria to ensure learning is relevant and purposeful.

## Curriculum coverage

Teaching Hub Level 7 topics	Strand	Vic Curric 2.0	Content description
Number properties	Number	VC2M7N01 VC2M7N02	<p>describe the relationship between perfect square numbers and square roots, and use squares of numbers and square roots of perfect square numbers to solve problems</p> <p>represent natural numbers in expanded notation using powers of 10, and as products of prime numbers using exponent notation</p>
Operations with decimals	Number	VC2M7N04 VC2M7N05 VC2M7N06	<p>round decimals to a given accuracy appropriate to the context and use appropriate rounding and estimation to check the reasonableness of computations</p> <p>multiply and divide fractions and decimals using efficient mental and written strategies, and digital tools</p> <p>use the 4 operations with positive rational numbers including fractions, decimals and percentages to solve problems using efficient calculation strategies</p>
Fractions, decimals and percentages	Number	VC2M7N03 VC2M7N06 VC2M7N07	<p>find equivalent representations of rational numbers and represent positive and negative rational numbers and mixed numbers on a number line</p> <p>find percentages of quantities and express one quantity as a percentage of another, with and without digital tools</p> <p>use the 4 operations with positive rational numbers including fractions, decimals and percentages to solve problems using efficient calculation strategies</p>
Operations with fractions	Number	VC2M7N05 VC2M7N06	<p>multiply and divide fractions and decimals using efficient mental and written strategies, and digital tools</p> <p>use the 4 operations with positive rational numbers including fractions, decimals and percentages to solve problems using efficient calculation strategies</p>
Modelling with fractions, decimals and percentages	Number	VC2M7N06 VC2M7N10	<p>use the 4 operations with positive rational numbers including fractions, decimals and percentages to solve problems using efficient calculation strategies</p> <p>use mathematical modelling to solve practical problems involving rational numbers and percentages, including financial contexts such as 'best buys'; formulate problems, choosing representations and efficient calculation strategies, designing algorithms and using digital tools as appropriate; interpret and communicate solutions in terms of the situation, justifying choices made about the representation</p>
Integers	Number	VC2M7N08	compare, order and solve problems involving addition and subtraction of integers
Understanding ratios	Number	VC2M7N09	recognise, represent and solve problems involving ratios

Algebra (variables and substitution)	Algebra	VC2M7A01 VC2M7A02	<p>recognise and use variables to represent everyday formulas algebraically and substitute values into formulas to determine an unknown</p> <p>apply the associative, commutative and distributive laws to aid mental and written computation, and formulate algebraic expressions using constants, variables, operations and brackets</p>
Linear relationships	Algebra	VC2M7A04 VC2M7A05	<p>investigate, interpret and describe relationships between variables represented in graphs of functions developed from authentic data</p> <p>generate tables of values from visually changing patterns or the rule of a function; describe and plot these relationships on the Cartesian plane</p>
Making and reading linear graphs	Algebra	VC2M7A04	investigate, interpret and describe relationships between variables represented in graphs of functions developed from authentic data
Solving linear equations	Algebra	VC2M7A03	solve one-variable linear equations of increasing complexity with natural number solutions; verify equation solutions by substitution
<i>[Activity – coming soon]</i>	Algebra	VC2M7A06	manipulate formulas involving several variables using digital tools, and describe the effect of systematic variation in the values of the variables
Area and volume	Measurement	VC2M7M01 VC2M7M02	<p>establish the formulas for areas of rectangles, triangles and parallelograms and use these in problem-solving</p> <p>solve problems involving the volume of right prisms including rectangular and triangular prisms, using established formulas and appropriate units</p>
Circles (features and circumference)	Measurement	VC2M7M03	describe the relationship between $\pi$ and the circumference, radius and diameter of a circle
Angles and transversals	Measurement	VC2M7M04 VC2M7M05	<p>identify corresponding, alternate and co-interior relationships between angles formed when parallel lines are crossed by a transversal; use them to solve problems and explain reasons</p> <p>demonstrate that the interior angle sum of a triangle in the plane is <math>180^\circ</math> and apply this to determine the interior angle sum of other shapes and the size of unknown angles</p>
Modelling with ratios and measurement	Measurement	VC2M7M06	use mathematical modelling to solve practical problems involving ratios of lengths, areas and volumes; formulate problems, interpret and communicate solutions in terms of the situation, justifying choices made about the representation
Visualising 3D	Space	VC2M7SP01	represent three dimensional objects in 2 dimensions; discuss and reason about the advantages and disadvantages of different representations
Triangles and quadrilaterals	Space	VC2M7SP02	classify triangles, quadrilaterals and other polygons according to their side and angle properties; identify and reason about relationships
Translations, reflections and rotations	Space	VC2M7SP03	describe the effect of transformations of a set of points using coordinates in the Cartesian plane, including translations and reflections in an axis, and rotations about the origin
<i>[Activity – coming soon]</i>	Space	VC2M7SP04	design algorithms involving a sequence of steps and decisions that will sort and classify sets of shapes according to their attributes, and describe how the algorithms work
Data and measures of central tendency	Statistics	VC2M7ST01	acquire data sets for discrete and continuous numerical variables and calculate the range, median, mean and mode; make and justify decisions about which measures of central tendency provide useful insights into the nature of the distribution of data

Displaying and understanding data	Statistics	VC2M7ST02	create different types of numerical data displays including dot plots and stem-and-leaf plots using software where appropriate; describe and compare the distribution of data, commenting on the shape, centre and spread including outliers and determining the range, median, mean and mode
<i>[Activity – coming soon]</i>	Statistics	VC2M7ST03	plan and conduct statistical investigations for issues involving discrete and continuous numerical data, and data collected from primary and secondary sources; analyse and interpret distributions of data and report findings in terms of shape and summary statistics
Probability (simulations and sample space)	Statistics	VC2M7P01 VC2M7P02	<p>identify the sample space for single-stage events; assign probabilities to the possible outcomes and predict relative frequencies for related events</p> <p>conduct repeated chance experiments and run simulations with a large number of trials using digital tools; compare predicted with observed results, explaining the differences and the effect of the sample size on the outcomes</p>

The Victorian Curriculum F-10 content elements are © VCAA

## Year planner

Term	Pearson Secondary Teaching Hub topics
Term 1	Number properties Operations with decimals Fractions, decimals and percentages Operations with fractions Modelling with fractions, decimals and percentages
Term 2	Integers Understanding ratios Algebra (variables and substitution) Linear relationships Making and reading linear graphs
Term 3	Solving linear equations Area and volume Circles (features and circumference) Angles and transversals Modelling with ratios and measurement Visualising 3D
Term 4	Triangles and quadrilaterals Translations, reflections and rotations Data and measures of central tendency Displaying and understanding data Probability (simulations and sample space)

# Features and support

## Phase: Activate prior knowledge

### Pearson Diagnostic

These quizzes are mapped to each topic and are designed to diagnose misconceptions and levels of understanding. Based on the results of these quizzes, each student receives personalised targeted activities to overcome misconceptions and upskill to ensure they are working at level for longer.

### Lesson warm-up

Every lesson begins with a lesson warm-up. This activity is designed to engage students in the lesson content and activate prior knowledge.

Every lesson warm-up comes complete with Teaching Notes (teacher view only), where teachers are supported with a suggested timeframe, any materials required, enabling and extending prompts and sample solutions.

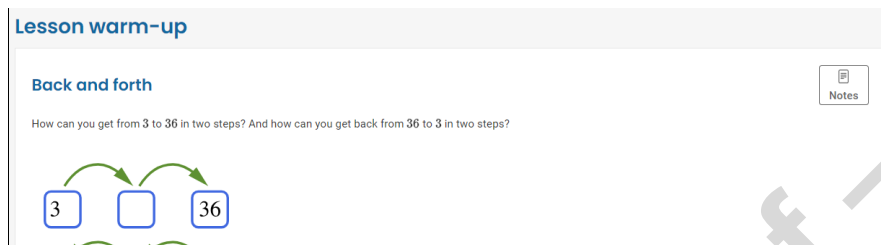

The screenshot shows a lesson warm-up interface. At the top, it says "Lesson warm-up" and "Back and forth". Below this, a question asks: "How can you get from 3 to 36 in two steps? And how can you get back from 36 to 3 in two steps?". A diagram shows a box with the number 3, an empty box, and a box with the number 36. Green arrows indicate a path from 3 to the empty box, and from the empty box to 36. A "Notes" icon is visible in the top right corner.

## Phase: Setting Learning Goals

The resources in Pearson Secondary Teaching Hub have been specifically created to support teachers and students.

The topics comprise lessons, the purpose of each lesson is defined by a learning intention and success criteria.

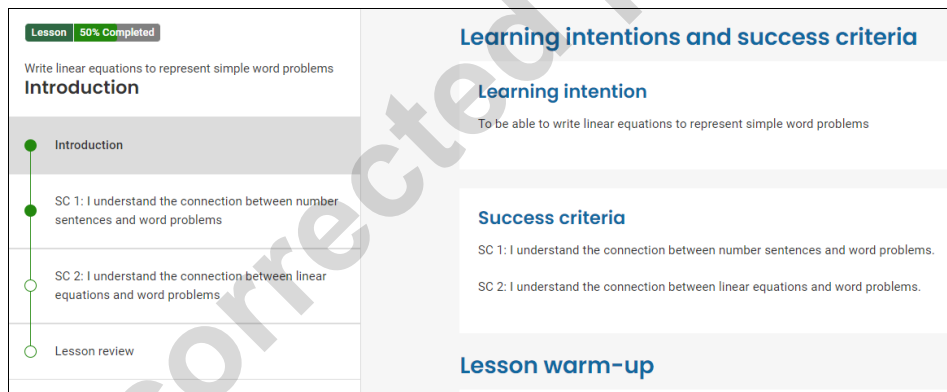

The screenshot displays a lesson page. On the left, a progress indicator shows "Lesson | 50% Completed". Below this, the lesson title is "Write linear equations to represent simple word problems" and the section is "Introduction". A vertical progress bar shows four steps: "Introduction" (completed), "SC 1: I understand the connection between number sentences and word problems" (completed), "SC 2: I understand the connection between linear equations and word problems" (in progress), and "Lesson review" (not started). The main content area is titled "Learning intentions and success criteria". Under "Learning intention", it states: "To be able to write linear equations to represent simple word problems". Under "Success criteria", it lists: "SC 1: I understand the connection between number sentences and word problems." and "SC 2: I understand the connection between linear equations and word problems." At the bottom, there is a section for "Lesson warm-up".

The hub gives access to Years 7 – 10 (Australian and Victorian curricula) and Stages 4 and 5 (NSW syllabus) content to ensure all students can access content at a suitable entry point and can be extended.

## Phase: Presentation (I do)

The demonstration phase of learning is supported with worked examples in the digital platform that are also presented as a video demonstration.

Success criteria have at least one worked example which is further supported with:

- a video walkthrough 'See it as a video'
- a try yourself example in the Student Companion
- 1-3 autocorrecting 'Check your understanding' questions to assess student readiness to progress from guided practice to independent practice.

Thinking	Working
Identify the operations in the equation.	The operation $-$ is subtraction. The symbol $=$ means 'equals'.
Identify the unknown value or variable.	The unknown value or variable is $x$ .
List words that can be used to describe the operations and symbols.	subtract, difference, take away, less than, decrease equal, the same as
Write the equation using words.	Examples: Subtracting 3 from an unknown number $x$ is the same as 8. 3 less than an unknown number $x$ is equal to 8. The difference between an unknown number $x$ and 3 is 8.

## Phase: Guided Practice (We do)

Each of the digital lessons, contains approximately 1-2 corresponding pages in the Student Companion providing a place for guided practice. The ‘try yourself’ format of the worked example gives students the opportunity to practice the required skill or skills with the support of their teacher.

### Equations

**Write linear equations to represent simple word problems**

**Learning intention:** To be able to write linear equations to represent simple word problems

**Success criteria:**

SC 1: I understand the connection between number sentences and word problems.

SC 2: I understand the connection between linear equations and word problems.

**SC 1: I understand the connection between number sentences and word problems**

**Worked example: Writing a number sentence using words**

Write  $10 - 4 = 6$  as a sentence using words.

Thinking	Working
Identify the operations or symbols used.	
List words that can be used to describe the operations and symbols.	
Write the sentence using words.	

1 Write each number sentence using words.

(a)  $11 + 7 = 18$  \_\_\_\_\_

(b)  $18 - 7 = 11$  \_\_\_\_\_

(c)  $2 \times 9 = 18$  \_\_\_\_\_

(d)  $18 \div 2 = 9$  \_\_\_\_\_

2 Write a list of words or phrases that can describe each operation or symbol.

+	−	×	÷	=
add				
sum				

## Phase: Independent Practice (You do)

Independent practice is supported in the digital lesson.

Each success criteria contains a ‘Practice’ section with approximately 4–6 exercise questions available in both the Student Book and in Hub.

### Practice

Complete the following exercise questions in your notebook.

1 Write each equation using words.

(a)  $x + 3 = 12$

(b)  $x - 3 = 12$

(c)  $3x = 12$

(d)  $\frac{x}{3} = 12$

Answer

2 The equations  $3x + 2 = 12$  and  $3(x + 2) = 12$  have the same numbers and operations. Will the value of  $x$  be the same in both equations? Explain.

Answer

3 Decide whether each pair of expressions are always equal, never equal or sometimes equal. Justify your answer with calculations.

(a)  $m + 3$  and  $3 + m$

(b)  $t - 3$  and  $3 - t$

(c)  $3 \times p$  and  $p \times 3$

(d)  $d \div 3$  and  $3 \div d$

Answer

4 Write the following using bold numerals and mathematical symbols.

(a) Multiply an unknown number  $n$  by 2 to give the answer 11.

(b) Add 7 to a number to give the answer 11.

COMING SOON

The teaching program will supply sample student navigation to support differentiation with a layered curriculum.



# Sample scope and sequence

## TERM 1

### TOPIC 1: NUMBER PROPERTIES

**Content descriptions:**

VC2M7N01 describe the relationship between perfect square numbers and square roots, and use squares of numbers and square roots of perfect square numbers to solve problems

VC2M7N02 represent natural numbers in expanded notation using powers of 10, and as products of prime numbers using exponent notation







*The Victorian Curriculum F-10 content elements are © VCAA*

**Pearson Diagnostic quizzes**

- Subtraction facts
- Multiplication facts (tables)
- Division facts
- Meaning of multiplication
- Multiplication and division with 1 and 0
- Multiplication and division by powers of 10
- Addition facts
- Order of operations
- Relational thinking
- Choosing multiplication and division operations
- Prime, composite and square numbers
- Factors and multiples
- Relational thinking

TERM 1: Weeks 1–2

Lesson name	Learning intention and success criteria	Differentiating independent practice	Annotations, other resources, teacher sign off
Understand and calculate squares and square roots	<b>Learning intention:</b> To understand and calculate squares and square roots		
	<b>Success criteria:</b> SC 1: I can identify square numbers. SC 2: I can determine the square root of a square number. SC 3: I can place the square root of any number between its two closest natural numbers.		
	SC 4: I can apply squares and square roots to real-life situations.		
Understand and use exponent	<b>Learning intention:</b> To understand and use exponent notation to		

notation to represent numbers	<p>represent numbers</p> <p><b>Success criteria:</b>                      SC 1: I can correctly use the terms 'base' and 'exponent'.                      SC 2: I can express repeated multiplication by using exponent notation.</p>			
Represent numbers in prime factor form	<p><b>Learning intention:</b> To be able to represent numbers in prime factor form</p> <p><b>Success criteria:</b>                      SC 1: I can determine the prime factors of a number.                      SC 2: I can use a factor ladder to determine the prime factors of a number.                      SC 3: I can use a factor tree to determine the prime factors of a number.                      SC 4: I can write a number as a product of its prime factors.</p>			
Understand and identify common factors	<p><b>Learning intention:</b> To understand and identify common factors</p> <p><b>Success criteria:</b>                      SC 1: I can determine the highest common factor (HCF) of a pair of numbers.                      SC 2: I can determine the lowest common multiple (LCM) of a pair of numbers.                      SC 3: I can solve problems involving highest common factors and lowest common multiples.</p>			
Understand and use expanded notation to represent numbers	<p><b>Learning intention:</b> To understand and use expanded notation to represent numbers</p> <p><b>Success criteria:</b>                      SC 1: I can write large powers of ten in both expanded form and exponent form.                      SC 2: I can write large numbers in expanded form.</p>			
				
				

## TOPIC 2: OPERATIONS WITH DECIMALS

**Content descriptions:**

VC2M7N04 round decimals to a given accuracy appropriate to the context and use appropriate rounding and estimation to check the reasonableness of computations

VC2M7N05 multiply and divide fractions and decimals using efficient mental and written strategies, and digital tools

VC2M7N06 use the 4 operations with positive rational numbers including fractions, decimals and percentages to solve problems using efficient calculation strategies

NOTE: VC2M7N06 is split into four topics in Pearson Secondary Teaching Hub

- Operations with decimals
- Fractions, decimals and percentages
- Operations with fractions
- Modelling with fractions, decimals and percentages

The Victorian Curriculum F-10 content elements are © VCAA

**Pearson Diagnostic quizzes**

- Understanding decimals

TERM 1: Weeks 3–4

Lesson name	Learning intention and success criteria	Differentiating independent practice	Annotations, other resources, teacher sign off
Round decimals for different purposes	<p><b>Learning intention:</b> To be able to round decimals for different purposes</p> <p><b>Success criteria:</b></p> <p>SC 1: I can round decimal values to any stated number of decimal places.</p> <p>SC 2: I can round decimals on a number line.</p> <p>SC 3: I can choose an appropriate level of accuracy in practical situations.</p>		
Add and subtract decimals	<p><b>Learning intention:</b> To be able to add and subtract decimals</p> <p><b>Success criteria:</b></p> <p>SC 1: I can model decimal addition and subtraction.</p> <p>SC 2: I can add and subtract decimals with the same number of decimal places.</p> <p>SC 3: I can add and subtract decimals with different numbers of decimal places.</p>		

	Multiply decimals	<p><b>Learning intention:</b> To be able to multiply decimals</p> <p><b>Success criteria:</b>                      SC 1: I can model multiplication of decimals by integers on a number line.</p>		
		<p>SC 2: I can multiply decimals by integers.</p> <p>SC 3: I can multiply decimals by powers of 10.</p>		
		<p>SC 4: I can multiply decimals by decimals.</p>		
	Divide decimals	<p><b>Learning intention:</b> To be able to divide decimals</p> <p><b>Success criteria:</b>                      SC 1: I can model division of decimals by integers on a number line.</p>		
<p>SC 2: I can divide decimals by integers.</p> <p>SC 3: I can divide decimals by powers of 10.</p>				
<p>SC 4: I can divide decimals by decimals.</p>				

Uncorrected proof – sample only

## TOPIC 3: FRACTIONS, DECIMALS AND PERCENTAGES

**Content descriptions:**

VC2M7N03 find equivalent representations of rational numbers and represent positive and negative rational numbers and mixed numbers on a number line

VC2M7N06 find percentages of quantities and express one quantity as a percentage of another, with and without digital tools

VC2M7N07 use the 4 operations with positive rational numbers including fractions, decimals and percentages to solve problems using efficient calculation strategies

NOTE: VC2M7N06 is split into four topics in Pearson Secondary Teaching Hub

- Operations with decimals
- Fractions, decimals and percentages
- Operations with fractions
- Modelling with fractions, decimals and percentages

*The Victorian Curriculum F-10 content elements are © VCAA*

**Pearson Diagnostic quizzes**

- Equivalent fractions (primary)
- Fraction models and meaning
- Percentage estimation

TERM 1: Weeks 5–6

Lesson name	Learning intention and success criteria	Differentiating independent practice	Annotations, other resources, teacher sign off
Understand and create equivalent fractions	<p><b>Learning intention:</b> To understand and create equivalent fractions</p> <p><b>Success criteria:</b> SC 1: I can use a model to create equivalent fractions. SC 2: I can write a string of equivalent fractions.</p>		
Determine the lowest common denominator and compare fractions	<p><b>Learning intention:</b> To be able to determine the lowest common denominator and compare fractions</p> <p><b>Success criteria:</b> SC 1: I can determine the lowest common denominator and use it to compare fractions.</p>		

Simplify fractions	<p><b>Learning intention:</b> To be able to simplify fractions</p> <p><b>Success criteria:</b>            SC 1: I can determine the highest common factor for a string of values.            SC 2: I can simplify fractions.</p>	Blue	
		Green	
		Orange	
Understand the relationship between decimals, percentages and fractions	<p><b>Learning intention:</b> To understand the relationship between decimals, percentages and fractions</p> <p><b>Success criteria:</b>            SC 1: I understand the connection between place value, decimals and fractions.            SC 2: I can write a decimal as a fraction.            SC 3: I can write a decimal as a percentage.            SC 4: I can convert between fractions, decimals and percentages.</p>	Blue	
		Green	
		Orange	
		Orange	
Locate fractions and decimals on a number line	<p><b>Learning intention:</b> To be able to locate fractions and decimals on a number line</p> <p><b>Success criteria:</b>            SC 1: I can divide 1 into equal parts to locate fractions between 0 and 1.            SC 2: I can divide 1 into equal parts to locate decimals between 0 and 1.</p>	Blue	
		Green	
		Orange	
Compare fractions and decimals on a number line	<p><b>Learning intention:</b> To be able to compare fractions and decimals on a number line</p> <p><b>Success criteria:</b>            SC 1: I can locate and compare decimals and fractions on a number line without graduation marks.            SC 2: I can locate and compare positive and negative numbers on a number line.</p>	Blue	
		Green	
		Orange	

## TOPIC 4: OPERATIONS WITH FRACTIONS

**Content descriptions:**

VC2M7N05 multiply and divide fractions and decimals using efficient mental and written strategies, and digital tools

VC2M7N06 use the 4 operations with positive rational numbers including fractions, decimals and percentages to solve problems using efficient calculation strategies

NOTE: VC2M7N06 is split into four topics in Pearson Secondary Teaching Hub

- Operations with decimals
- Fractions, decimals and percentages
- Operations with fractions
- Modelling with fractions, decimals and percentages

The Victorian Curriculum F-10 content elements are © VCAA

**Pearson Diagnostic quizzes**

- |  |   |
|--|---|
| <input type="checkbox"/> Fraction models (primary)                   | <input type="checkbox"/> Fraction division (primary)    |
| <input type="checkbox"/> Fraction addition and subtraction (primary) | <input type="checkbox"/> Fraction operations (concepts) |
| <input type="checkbox"/> Fraction multiplication (primary)           | <input type="checkbox"/> Fraction operations (skills)   |

TERM 1: Weeks 7–8

Lesson name	Learning intention and success criteria	Differentiating independent practice	Annotations, other resources, teacher sign off
Understand how to add and subtract fractions	<p><b>Learning intention:</b> To understand how to add and subtract fractions</p> <p><b>Success criteria:</b>                      SC 1 I can add and subtract fractions with the same denominator.                      SC 2: I can add and subtract fractions with related denominators.                      SC 3: I can add and subtract fractions with unrelated denominators.</p>		
Understand mixed numbers and improper fractions	<p><b>Learning intention:</b> To understand mixed numbers and improper fractions</p> <p><b>Success criteria:</b>                      SC 1: I can convert between improper fractions and mixed numbers.                      SC 2: I can add and subtract mixed numbers.</p>		

	Find the fraction of an amount	<p><b>Learning intention:</b> To be able to find the fraction of an amount</p> <p><b>Success criteria:</b> SC 1: I can multiply fractions by whole numbers.</p> <p>SC 2: I can find a fraction of an amount.</p>	Blue	
			Green	
			Orange	
	Understand how to multiply fractions	<p><b>Learning intention:</b> To understand how to multiply fractions</p> <p><b>Success criteria:</b> SC 1: I can multiply fractions using an area model.</p> <p>SC 2: I can multiply fractions using numerical methods.</p>	Blue	
			Green	
			Orange	
	Understand how to divide fractions	<p><b>Learning intention:</b> To understand how to divide fractions</p> <p><b>Success criteria:</b> SC 1: I can divide an integer by a fraction using a diagram.</p> <p>SC 2: I can divide an integer by a fraction by multiplying by the reciprocal.</p> <p>SC 3: I can divide a fraction by an integer.</p> <p>SC 4: I can divide fractions.</p>	Blue	
			Green	
			Orange	

Uncorrected proof – sample only

## TOPIC 5: MODELLING WITH FRACTIONS, DECIMALS AND PERCENTAGES

**Content descriptions:**

VC2M7N06 use the 4 operations with positive rational numbers including fractions, decimals and percentages to solve problems using efficient calculation strategies

VC2M7N10 use mathematical modelling to solve practical problems involving rational numbers and percentages, including financial contexts such as ‘best buys’; formulate problems, choosing representations and efficient calculation strategies, designing algorithms and using digital tools as appropriate; interpret and communicate solutions in terms of the situation, justifying choices made about the representation

NOTE: VC2M7N06 is split into four topics in Pearson Secondary Teaching Hub

- Operations with decimals
- Fractions, decimals and percentages
- Operations with fractions
- Modelling with fractions, decimals and percentages

The Victorian Curriculum F-10 content elements are © VCAA

**Pearson Diagnostic quizzes**

- |   |  |
|---|--|
| <input type="checkbox"/> Percentage estimation        | <input type="checkbox"/> Percentage strategies |
| <input type="checkbox"/> Calculating with proportions | <input type="checkbox"/> Percentage change     |
| <input type="checkbox"/> Percentage problem types     |  |

TERM 1: Weeks 9–10

Lesson name	Learning intention and success criteria		Differentiating independent practice	Annotations, other resources, teacher sign off
Choose an appropriate representation to solve problems	<p><b>Learning intention:</b> To be able to choose an appropriate representation to solve problems</p> <p><b>Success criteria:</b></p> <p>SC 1: I can identify common equivalent forms for fractions, decimals and percentages.</p> <p>SC 2: I can choose the best representation to solve problems.</p>			
Determine the proportion of a quantity	<p><b>Learning intention:</b> To be able to determine the proportion of a quantity</p> <p><b>Success criteria:</b></p> <p>SC 1: I can determine the stated proportion, expressed as a decimal, fraction or percentage, of a real</p>			

	<p>number.</p> <p>SC 2: I can determine the proportion, expressed as a decimal, fraction or percentage, that one quantity represents of another.</p>		
Understand percentage as applied to taxation	<p><b>Learning intention:</b> To understand percentage as applied to taxation</p> <p><b>Success criteria:</b></p> <p>SC 1: I can determine the GST payable.</p> <p>SC 2: I can interpret income tax tables and use them to determine tax payable.</p>		
Use fractions, decimals and percentages to solve financial problems	<p><b>Learning intention:</b> To be able to use fractions, decimals and percentages to solve financial problems</p> <p><b>Success criteria:</b></p> <p>SC 1: I can define, and use in calculations, the terms profit, loss, cost price, selling price and discount.</p> <p>SC 2: I can calculate the profit or loss on an item and express this as a percentage of the cost price or the selling price.</p>		
Use, interpret and calculate discounts and mark-ups	<p><b>Learning intention:</b> To be able to use, interpret and calculate discounts and mark-ups</p> <p><b>Success criteria:</b></p> <p>SC 1: I can calculate a percentage discount.</p> <p>SC 2: I can calculate a percentage mark-up.</p>		

# TERM 2

## TOPIC 6: INTEGERS

**Content descriptions:**

VC2M7N08 compare, order and solve problems involving addition and subtraction of integers

The Victorian Curriculum F-10 content elements are © VCAA

**Pearson Diagnostic quizzes**

- |   |  |
|---|--|
| <input type="checkbox"/> Addition facts                           | <input type="checkbox"/> Multiplication and division by powers of 10   |
| <input type="checkbox"/> Subtraction facts                        | <input type="checkbox"/> Order of operations                           |
| <input type="checkbox"/> Multiplication facts (tables)            | <input type="checkbox"/> Readiness for operations with directed number |
| <input type="checkbox"/> Division facts                           | <input type="checkbox"/> Reading scales                                |
| <input type="checkbox"/> Meaning of multiplication                | <input type="checkbox"/> Relational thinking                           |
| <input type="checkbox"/> Multiplication and division with 1 and 0 | <input type="checkbox"/> Operations with integers                      |

TERM 2: Weeks 1–2

Lesson name	Learning intention and success criteria	Differentiating independent practice	Annotations, other resources, teacher sign off
Understand integers and operations	<p><b>Learning intention:</b> To understand integers and operations</p> <p><b>Success criteria:</b>                      SC 1: I can plot integers on a number line.                      SC 2: I can compare and order integers.                      SC 3: I can determine the magnitude and direction of integers.</p>		
Add and subtract integers	<p><b>Learning intention:</b> To be able to add and subtract integers</p> <p><b>Success criteria:</b>                      SC 1: I can add integers.                      SC 2: I can subtract integers.                      SC 3: I can perform addition and subtraction of integers using different strategies.</p>		
Model and solve practical problems	<p><b>Learning intention:</b> To be able to model and solve practical problems using integers</p>		

	using integers	<p><b>Success criteria:</b></p> <p>SC 1: I can apply integer operations to word problems.</p> <p>SC 2: I can represent profit and loss as positive and negative values.</p> <p>SC 3: I can use integers to model and solve practical problems.</p>	<div style="background-color: green; height: 100%;"></div> <div style="background-color: orange; height: 100%;"></div>		
--	----------------	--	--	--	--

Uncorrected proof – sample only

## TOPIC 7: UNDERSTANDING RATIOS

**Content descriptions:**

VC2M7N09 recognise, represent and solve problems involving ratios

*The Victorian Curriculum F-10 content elements are © VCAA*

**Pearson Diagnostic quizzes**

Comparing ratios

TERM 2: Weeks 3–4

Lesson name	Learning intention and success criteria	Differentiating independent practice	Annotations, other resources, teacher sign off
Write ratios	<p><b>Learning intention:</b> To be able to write ratios</p> <p><b>Success criteria:</b>                      SC 1: I can write ratios to represent a diagram.                      SC 2: I can use ratios to translate simple statements.</p>		
Understand equivalent ratios	<p><b>Learning intention:</b> To understand equivalent ratios</p> <p><b>Success criteria:</b>                      SC 1: I can write ratios in simplest form.                      SC 2: I can compare quantities using ratios.</p>		
Understand the connection between fractions and ratios	<p><b>Learning intention:</b> To understand the connection between fractions and ratios</p> <p><b>Success criteria:</b>                      SC 1: I can convert ratios to describe the relationship between parts and the whole.                      SC 2: I can convert fractions of the whole to part : part ratios.                      SC 3: I can share quantities into given ratios.</p>		

## TOPIC 8: ALGEBRA (VARIABLES AND SUBSTITUTION)

**Content descriptions:**

VC2M7A01 recognise and use variables to represent everyday formulas algebraically and substitute values into formulas to determine an unknown

VC2M7A02 apply the associative, commutative and distributive laws to aid mental and written computation, and formulate algebraic expressions using constants, variables, operations and brackets

*The Victorian Curriculum F-10 content elements are © VCAA*

**Pearson Diagnostic quizzes**

- |  |   |
|--|---|
| <input type="checkbox"/> Relational thinking<br><br><input type="checkbox"/> Values for letters<br><br><input type="checkbox"/> Letters for numbers or objects | <input type="checkbox"/> Writing expressions involving multiplication, addition and subtraction<br><br><input type="checkbox"/> Formulating algebraic expressions |
|--|---|

**TERM 2: Weeks 5–6**

Lesson name	Learning intention and success criteria	Differentiating independent practice	Annotations, other resources, teacher sign off
Understand variables in algebra	<b>Learning intention:</b> To understand variables in algebra  <b>Success criteria:</b> SC 1: I can create algebraic expressions using variables.  SC 2: I can write algebraic expressions involving all four operations.		
	SC 1: I can create algebraic expressions using variables.  SC 2: I can write algebraic expressions involving all four operations.		
	SC 2: I can write algebraic expressions involving all four operations.		
Identify and simplify like terms	<b>Learning intention:</b> To be able to identify and simplify like terms  <b>Success criteria:</b> SC 1: I can identify like terms.  SC 2: I can simplify expressions by adding and subtracting like terms.		
	SC 1: I can identify like terms.  SC 2: I can simplify expressions by adding and subtracting like terms.		
	SC 2: I can simplify expressions by adding and subtracting like terms.		
Calculate the value of algebraic expressions	<b>Learning intention:</b> To be able to calculate the value of algebraic expressions  <b>Success criteria:</b> SC 1: I can substitute values to evaluate algebraic expressions.  SC 2: I can create number patterns by substituting values into algebraic expressions.		
	SC 1: I can substitute values to evaluate algebraic expressions.  SC 2: I can create number patterns by substituting values into algebraic expressions.		

		SC 3: I can substitute values in practical situations.			
	Write algebraic expressions in context	<b>Learning intention:</b> To be able to write algebraic expressions in context			
		<b>Success criteria:</b> SC 1: I can use mathematical variables and relationships to explore real-life processes.			

Uncorrected proof – sample only

## TOPIC 9: LINEAR RELATIONSHIPS

**Content descriptions:**

VC2M7A04 investigate, interpret and describe relationships between variables represented in graphs of functions developed from authentic data

VC2M7A05 generate tables of values from visually changing patterns or the rule of a function; describe and plot these relationships on the Cartesian plane

*The Victorian Curriculum F-10 content elements are © VCAA*

**Pearson Diagnostic quizzes**

- |   |  |
|---|--|
| <input type="checkbox"/> Values for letters   | <input type="checkbox"/> Formulating algebraic expressions |
| <input type="checkbox"/> Letters for numbers or objects   | <input type="checkbox"/> Plotting coordinates              |
| <input type="checkbox"/> Writing expressions involving multiplication, addition and subtraction | <input type="checkbox"/> Grid references and coordinates   |

**TERM 2: Weeks 7–8**

Lesson name	Learning intention and success criteria	Differentiating independent practice	Annotations, other resources, teacher sign off
Understand the components of an equation and how they are combined	<b>Learning intention:</b> To understand the components of an equation and how they are combined  <b>Success criteria:</b> SC 1: I can explain the difference between an expression and an equation.		
	SC 1: I can explain the difference between an expression and an equation.		
	SC 1: I can explain the difference between an expression and an equation.		
Generate a table of values using a linear equation	<b>Learning intention:</b> To be able to generate a table of values using a linear equation  <b>Success criteria:</b> SC 1: I can substitute numbers into an equation to determine the value of a variable.  SC 2: I can generate a table of values from a linear equation.  SC 3: I can describe the rule connecting variables in a table of values.		
	SC 1: I can substitute numbers into an equation to determine the value of a variable.		
	SC 2: I can generate a table of values from a linear equation.  SC 3: I can describe the rule connecting variables in a table of values.		
Recognise the connection between	<b>Learning intention:</b> To be able to recognise the connection between points on a Cartesian plane, a table of		

	points on a Cartesian plane, a table of values and a linear pattern	values and a linear pattern <b>Success criteria:</b> SC 1: I can represent a table of coordinate values on a Cartesian plane.  SC 2: I can recognise a linear pattern from a set of points on a Cartesian plane and create a table of values.  SC 3: I can recognise and describe consistent changes in the values of coordinates and link them to a linear pattern.			
	Model linear patterns using manipulatives, diagrams and graphs	<b>Learning intention:</b> To be able to model linear patterns using manipulatives, diagrams and graphs  <b>Success criteria:</b> SC 1: I can use manipulatives or draw diagrams to model a linear pattern.			

Uncorrected proof – sample only

## TOPIC 10: MAKING AND READING LINEAR GRAPHS

**Content descriptions:**

VC2M7A04 investigate, interpret and describe relationships between variables represented in graphs of functions developed from authentic data

*The Victorian Curriculum F-10 content elements are © VCAA*

**Pearson Diagnostic quizzes**

- Relational thinking
- Reading scales
- Interpreting line graphs
- Plotting coordinates
- Grid references and coordinates

TERM 2: Weeks 9–10

Lesson name	Learning intention and success criteria	Differentiating independent practice	Annotations, other resources, teacher sign off
Graph linear relationships from a rule	<p><b>Learning intention:</b> To be able to graph linear relationships from a rule</p> <p><b>Success criteria:</b> SC 1: I can graph a linear relationship from a rule.</p> <p>SC 2: I can graph a linear relationship using the y-intercept.</p>		
Interpret the gradient of a linear graph	<p><b>Learning intention:</b> To be able to interpret the gradient of a linear graph</p> <p><b>Success criteria:</b> SC 1: I can classify the slope of a line as increasing, decreasing or zero.</p> <p>SC 2: I can interpret linear conversion graphs.</p>		
Interpret, discuss and analyse relationships in graphs	<p><b>Learning intention:</b> To be able to interpret, discuss and analyse relationships in graphs</p> <p><b>Success criteria:</b> SC 1: I can use graphs to interpret simple rates.</p> <p>SC 2: I can interpret and analyse travel graphs.</p> <p>SC 3: I can interpret and analyse time graphs.</p>		

# TERM 3

## TOPIC 11: SOLVING LINEAR EQUATIONS

**Content descriptions:**

VC2M7A03 solve one-variable linear equations of increasing complexity with natural number solutions; verify equation solutions by substitution

The Victorian Curriculum F-10 content elements are © VCAA

**Pearson Diagnostic quizzes**

- Values for letters
- Letters for numbers or objects
- Writing expressions involving multiplication, addition and subtraction
- Formulating algebraic expressions
- Solving linear equations
- Writing linear equations

TERM 3: Weeks 1–2

Lesson name	Learning intention and success criteria	Differentiating independent practice	Annotations, other resources, teacher sign off
Write linear equations to represent simple word problems	<p><b>Learning intention:</b> To be able to write linear equations to represent simple word problems</p> <p><b>Success criteria:</b></p> <p>SC 1: I understand the connection between number sentences and word problems.</p> <p>SC 2: I understand the connection between linear equations and word problems.</p>		
Write linear equations to represent diagrams and patterns	<p><b>Learning intention:</b> To be able to write linear equations to represent diagrams and patterns</p> <p><b>Success criteria:</b></p> <p>SC 1: I can formulate information in a diagram as a linear equation.</p> <p>SC 2: I can formulate information in a pattern as a linear equation.</p>		
Use flow charts to determine the value of an expression	<p><b>Learning intention:</b> To be able to use flow charts to determine the value of an expression</p> <p><b>Success criteria:</b></p> <p>SC 1: I can apply operations to a number and determine the result.</p> <p>SC 2: I can apply operations to a</p>		

	variable and determine the result.		
Use flow charts to solve linear equations	<b>Learning intention:</b> To be able to use flow charts to solve linear equations		
	<b>Success criteria:</b> SC 1: I can solve simple equations by inspection. SC 2: I can identify inverse operations to backtrack a flow chart and solve an equation.		
	<b>Learning intention:</b> To be able to use the balance method to solve linear equations		
Use the balance method to solve linear equations	<b>Success criteria:</b> SC 1: I understand how to keep an equation balanced. SC 2: I can use the balance method to solve a linear equation.		

Uncorrected proof – sample only

## TOPIC 12: AREA AND VOLUME

**Content descriptions:**

VC2M7M01 establish the formulas for areas of rectangles, triangles and parallelograms and use these in problem-solving

VC2M7M02 solve problems involving the volume of right prisms including rectangular and triangular prisms, using established formulas and appropriate units

*The Victorian Curriculum F-10 content elements are © VCAA*

**Pearson Diagnostic quizzes**

- |   |  |
|---|--|
| <input type="checkbox"/> Estimation (not counting)        | <input type="checkbox"/> Volume using litres                     |
| <input type="checkbox"/> Estimation of length             | <input type="checkbox"/> Volume using cubic measures             |
| <input type="checkbox"/> Length and area (basic concepts) | <input type="checkbox"/> Labelling base and height of a triangle |

TERM 3: Weeks 3–4

Lesson name	Learning intention and success criteria	Differentiating independent practice	Annotations, other resources, teacher sign off
Understand and convert between units of area	<b>Learning intention:</b> To understand and convert between units of area		
	<b>Success criteria:</b> SC 1: I understand units of area		
	SC 2: I can convert between units of area		
Calculate the area of a parallelogram	<b>Learning intention:</b> To be able to calculate the area of a parallelogram		
	<b>Success criteria:</b> SC 1: I can determine the area of a parallelogram by drawing a rectangle with the same area.		
	SC 2: I can calculate the area of a parallelogram using a formula.		
Calculate the area of a triangle	<b>Learning intention:</b> To be able to calculate the area of a triangle		
	<b>Success criteria:</b> SC 1: I can determine the area of a triangle as half of a rectangle.		
	SC 2: I can determine the area of a triangle as half of a parallelogram.  SC 3: I can calculate the area of a triangle using a formula.		

Understand volume measured in cubic units	<p><b>Learning intention:</b> To be able to use flow charts to solve linear equations</p> <p><b>Success criteria:</b></p> <p>SC 1: I can determine the volume of a solid by counting and visualising unit cubes.</p> <p>SC 2: I can create rectangular prisms with unit cubes.</p> <p>SC 3: I can determine the volume of rectangular prisms.</p>	Blue	
	Green		
	Orange		
Establish the volume formula and units for prisms	<p><b>Learning intention:</b> To establish the volume formula and units for prisms</p> <p><b>Success criteria:</b></p> <p>SC 1: I can apply the rectangular prism volume formula.</p> <p>SC 2: I can determine the volume of any solid of constant cross-sectional area.</p> <p>SC 3: I can determine the volume of a slanted prism.</p>	Blue	
	Green		
	Orange		
Explore the connection between volume and capacity	<p><b>Learning intention:</b> To be able to explore the connection between volume and capacity</p> <p><b>Success criteria:</b></p> <p>SC 1: I can determine the most suitable units of measurement for given containers.</p> <p>I can estimate volume and capacity.</p> <p>I can determine the capacity of containers.</p>	Blue	
	Green		
	Orange		

## TOPIC 13: CIRCLES (FEATURES AND CIRCUMFERENCE)

**Content descriptions:**

VC2M7M03 describe the relationship between  $\pi$  and the circumference, radius and diameter of a circle

*The Victorian Curriculum F-10 content elements are © VCAA*

**Pearson Diagnostic quizzes**

N/A

TERM 3: Weeks 5–6

Lesson name	Learning intention and success criteria	Differentiating independent practice	Annotations, other resources, teacher sign off
Recognise circle features	<p><b>Learning intention:</b> To be able to recognise circle features</p> <p><b>Success criteria:</b> SC 1: I can identify and define circles and their features. SC 2: I understand the relationship between the radius and diameter of a circle.</p>		
Understand how circumference is related to radius and diameter	<p><b>Learning intention:</b> To understand how circumference is related to radius and diameter</p> <p><b>Success criteria:</b> SC 1: I understand the relationship between the circumference, the radius and the diameter. SC 2: I can approximate the value of pi.</p>		
Solve length problems involving circles	<p><b>Learning intention:</b> To be able to solve length problems involving circles</p> <p><b>Success criteria:</b> SC 1: I can calculate circumference given the radius or diameter. SC 2: I can determine the length of a radius and diameter from a circumference. SC 3: I can calculate the perimeter of shapes involving circles.</p>		

## TOPIC 14: ANGLES AND TRANSVERSALS

**Content descriptions:**

VC2M7M04 identify corresponding, alternate and co-interior relationships between angles formed when parallel lines are crossed by a transversal; use them to solve problems and explain reasons

VC2M7M05 demonstrate that the interior angle sum of a triangle in the plane is  $180^\circ$  and apply this to determine the interior angle sum of other shapes and the size of unknown angles

*The Victorian Curriculum F-10 content elements are © VCAA*

**Pearson Diagnostic quizzes**

Understanding angle

TERM 3: Weeks 6–7

Lesson name	Learning intention and success criteria	Differentiating independent practice	Annotations, other resources, teacher sign off
Construct perpendicular and parallel lines	<b>Learning intention:</b> To be able to construct perpendicular and parallel lines		
	<b>Success criteria:</b> SC 1: I can construct perpendicular lines. SC 2: I can construct parallel lines. SC 3: I can construct shapes that involve parallel sides or perpendicular diagonals.		
Identify corresponding, alternate and co-interior angles	<b>Learning intention:</b> To be able to identify corresponding, alternate and co-interior angles		
	<b>Success criteria:</b> SC 1: I can identify angle relationships around a transversal. SC 2: I can determine the size of unknown angles involving parallel lines.		
Determine the exterior angle of a triangle	<b>Learning intention:</b> To be able to determine the exterior angle of a triangle		
	<b>Success criteria:</b> SC 1: I can use parallel lines to deduce the exterior angle property for triangles. SC 2: I can determine the size of unknown angles involving the exterior angle rule		

	<p>Internal angle sum of a triangle</p>	<p><b>Learning intention:</b> To be able to internal angle sum of a triangle</p> <p><b>Success criteria:</b></p> <p>SC 1: I can use parallel lines to deduce the angle sum of a triangle.</p> <p>SC 2: I can determine the angle sum of any polygon.</p> <p>SC 3: I can determine unknown angles involving the angle sum rules..</p>			
--	---	--	---	--	--

Uncorrected proof – sample only

## TOPIC 15: MODELLING WITH RATIOS AND MEASUREMENT

**Content descriptions:**

VC2M7M06 use mathematical modelling to solve practical problems involving ratios of lengths, areas and volumes; formulate problems, interpret and communicate solutions in terms of the situation, justifying choices made about the representation

*The Victorian Curriculum F-10 content elements are © VCAA*

**Pearson Diagnostic quizzes**

- |  |   |
|--|---|
| <input type="checkbox"/> Comparing ratios          | <input type="checkbox"/> Estimation of length             |
| <input type="checkbox"/> Estimation (not counting) | <input type="checkbox"/> Length and area (basic concepts) |

TERM 3: Week 8

Lesson name	Learning intention and success criteria	Differentiating independent practice	Annotations, other resources, teacher sign off
Solve practical problems involving ratios of length	<b>Learning intention:</b> To be able to solve practical problems involving ratios of length		
	<b>Success criteria:</b> SC 1: I can describe the change in length with enlargement. SC 2: I can determine an approximation for the ratio between measures of a circle. SC 3: I can solve practical problems involving ratios of length.		
Explore ratios in measured quantities	<b>Learning intention:</b> To be able to explore ratios in measured quantities		
	<b>Success criteria:</b> SC 1: I can make connections between length, area and volume ratios after scaling transformations. SC 2: I can apply and solve ratio problems involving mixtures		

## TOPIC 16: VISUALISING 3D

**Content descriptions:**

VC2M7SP01 represent three dimensional objects in 2 dimensions; discuss and reason about the advantages and disadvantages of different representations

*The Victorian Curriculum F-10 content elements are © VCAA*

**Pearson Diagnostic quizzes**

- Understanding angle
- Visualising solids and nets of solids
- Visualising 3D from 2D

TERM 3: Weeks 9–10

Lesson name	Learning intention and success criteria	Differentiating independent practice	Annotations, other resources, teacher sign off
Visualise and apply nets	<p><b>Learning intention:</b> To be able to visualise and apply nets</p>		
	<p><b>Success criteria:</b> SC 1: I can identify common shapes from nets.</p>		
	<p>SC 2: I can draw a net for any prism or pyramid.</p>		
Visualise and draw the perspective views of a 3D object	<p><b>Learning intention:</b> To be able to visualise and draw the perspective views of a 3D object</p>		
	<p><b>Success criteria:</b> SC 1: I can draw the perspective views of a 3D object.</p>		
	<p>SC 2: I can identify prisms within structures.</p>		
Draw and build objects made from cubes	<p><b>Learning intention:</b> To be able to draw and build objects made from cubes</p>		
	<p><b>Success criteria:</b> SC 1: I can build objects with cubes from isometric drawings and perspective drawings.</p>		
	<p>SC 2: I can draw a 2D representation of a 3D object using an isometric grid.</p>		
Draw and use objects represented in art form	<p><b>Learning intention:</b> To be able to draw and use objects represented in art form</p> <p><b>Success criteria:</b></p>		

	SC 1: I can represent objects in art form.		
	SC 2: I can use maps represented in art form.		

Uncorrected proof – sample only

# TERM 4

## TOPIC 17: TRIANGLES AND QUADRILATERALS

**Content descriptions:**

VC2M7SP02 classify triangles, quadrilaterals and other polygons according to their side and angle properties; identify and reason about relationships

The Victorian Curriculum F-10 content elements are © VCAA

**Pearson Diagnostic quizzes**

Understanding angle

TERM 4: Weeks 1–2

Lesson name	Learning intention and success criteria	Differentiating independent practice	Annotations, other resources, teacher sign off	
Construct triangles and quadrilaterals	<p><b>Learning intention:</b> To be able to visualise and apply nets</p> <p><b>Success criteria:</b> SC 1: I can determine whether or not a triangle can be formed from given side lengths. SC 2: I can construct a triangle given the three side lengths. SC 3: I can demonstrate that side lengths alone do not determine the shape of quadrilaterals.</p>	<div style="background-color: #0070C0; height: 20px; width: 100%;"></div> <div style="background-color: #4CAF50; height: 20px; width: 100%;"></div> <div style="background-color: #FFB300; height: 20px; width: 100%;"></div>		
	Classify types of triangles by their side and angle properties	<p><b>Learning intention:</b> To be able to classify types of triangles by their side and angle properties</p> <p><b>Success criteria:</b> SC 1: I can identify and sketch triangles according to their side properties. SC 2: I can identify and sketch triangles according to their angle properties. SC 3: I can categorise triangles using side lengths and angles.</p>	<div style="background-color: #0070C0; height: 20px; width: 100%;"></div> <div style="background-color: #4CAF50; height: 20px; width: 100%;"></div> <div style="background-color: #FFB300; height: 20px; width: 100%;"></div>	
		Classify types of quadrilaterals by their side and angle properties	<p><b>Learning intention:</b> To be able to classify types of quadrilaterals by their side and angle properties</p> <p><b>Success criteria:</b> SC 1: I can identify and describe the side and angle properties of quadrilaterals.</p>	<div style="background-color: #0070C0; height: 20px; width: 100%;"></div> <div style="background-color: #4CAF50; height: 20px; width: 100%;"></div>

		<p>SC 2: I can identify a hierarchy within types of quadrilaterals.</p> <p>SC 3: I can use a flowchart for polygons to categorise triangles and quadrilaterals.</p>			
	<p>Use parallel side lengths of quadrilaterals to construct rectangles of equivalent area</p>	<p><b>Learning intention:</b> To be able to use parallel side lengths of quadrilaterals to construct rectangles of equivalent area</p> <p><b>Success criteria:</b></p>			
		<p>SC 1: I can form quadrilaterals with parallel sides from appropriate pairs of triangles.</p> <p>SC 2: I can form a rectangle (or square) of equivalent area from any quadrilateral that has a pair of parallel sides.</p>			
		<p>SC 3: I can calculate the area of trapeziums using the average of parallel sides.</p>			

Uncorrected proof – sample only

## TOPIC 18: TRANSLATIONS, REFLECTIONS AND ROTATIONS

**Content descriptions:**

VC2M7SP03 describe the effect of transformations of a set of points using coordinates in the Cartesian plane, including translations and reflections in an axis, and rotations about the origin

*The Victorian Curriculum F-10 content elements are © VCAA*

**Pearson Diagnostic quizzes**

- Rotation
- Reflection
- Understanding angle

TERM 4: Week 3

Lesson name	Learning intention and success criteria	Differentiating independent practice	Annotations, other resources, teacher sign off
Translate and reflect points and shapes on a Cartesian plane	<b>Learning intention:</b> To be able to translate and reflect points and shapes on a Cartesian plane		
	<b>Success criteria:</b> SC 1: I can perform translations on a Cartesian plane.		
	SC 2: I can perform reflections in an axis.  SC 3: I can identify and describe translations and reflections.		
Rotate shapes on a Cartesian plane	<b>Learning intention:</b> To be able to rotate shapes on a Cartesian plane		
	<b>Success criteria:</b> SC 1: I can describe and perform rotations of shapes on a Cartesian plane.		
	SC 2: I can identify and describe combined transformations.		

## TOPIC 19: DATA AND MEASURES OF CENTRAL TENDENCY

**Content descriptions:**

VC2M7ST01 acquire data sets for discrete and continuous numerical variables and calculate the range, median, mean and mode; make and justify decisions about which measures of central tendency provide useful insights into the nature of the distribution of data

*The Victorian Curriculum F-10 content elements are © VCAA*

**Pearson Diagnostic quizzes**

- Choosing appropriate graphs
- Arithmetic average (mean)
- Understanding mean, median and mode

TERM 4: Weeks 4–5

Lesson name	Learning intention and success criteria	Differentiating independent practice	Annotations, other resources, teacher sign off
Understand different data types	<b>Learning intention:</b> To understand different data types		
	<b>Success criteria:</b> SC 1: I can classify data as primary or secondary.		
	SC 2: I can classify data as categorical or numerical. SC 3: I can classify numerical data as either continuous or discrete.		
Calculate the mean and range of a set of data	<b>Learning intention:</b> To be able to calculate the mean and range of a set of data		
	<b>Success criteria:</b> SC 1: I can calculate the range.		
	SC 2: I can calculate the mean. SC 3: I understand the impact on mean and range with extreme values.		
Calculate the mean and range for a set of grouped data	<b>Learning intention:</b> To be able to calculate the mean and range for a set of grouped data		
	<b>Success criteria:</b> SC 1: I can determine the mean and range from a frequency table.		
	SC 2: I can determine the mean and range from grouped data.		

	Determine the median of a data set	<p><b>Learning intention:</b> To be able to determine the median of a data set</p> <p><b>Success criteria:</b></p> <p>SC 1: I can determine the median of a set of raw data.</p> <p>SC 2: I can determine the median from a frequency table.</p>	<div style="background-color: #0070C0; width: 100%; height: 100%;"></div>	
	Determine an appropriate measure of central tendency	<p><b>Learning intention:</b> To be able to determine an appropriate measure of central tendency</p> <p><b>Success criteria:</b></p> <p>SC 1: I can identify the mode of a set of raw data and data in a frequency table.</p> <p>SC 2: I can choose which measure of central tendency is the most appropriate for a scenario.</p>	<div style="background-color: #0070C0; width: 100%; height: 100%;"></div>	

Uncorrected proof – sample only



## TOPIC 20: DISPLAYING AND UNDERSTANDING DATA

**Content descriptions:**

VC2M7ST02 create different types of numerical data displays including dot plots and stem-and-leaf plots using software where appropriate; describe and compare the distribution of data, commenting on the shape, centre and spread including outliers and determining the range, median, mean and mode

*The Victorian Curriculum F-10 content elements are © VCAA*

**Pearson Diagnostic quizzes**

- |   |  |
|---|--|
| <input type="checkbox"/> Interpreting pictographs | <input type="checkbox"/> Interpreting line graphs    |
| <input type="checkbox"/> Interpreting bar graphs  | <input type="checkbox"/> Choosing appropriate graphs |

TERM 4: Weeks 6–7

Lesson name	Learning intention and success criteria	Differentiating independent practice	Annotations, other resources, teacher sign off
Understand stem-and-leaf plots	<b>Learning intention:</b> To understand stem-and-leaf plots		
	<b>Success criteria:</b> SC 1: I can create and interpret a stem-and-leaf plot.		
	SC 2: I can create a split stem-and-leaf plot.		
Create and interpret statistical plots	<b>Learning intention:</b> To be able to create and interpret statistical plots		
	<b>Success criteria:</b> SC 1: I can construct and interpret dot plots.		
	SC 2: I can determine the range and mode of values from dot plots and stem-and-leaf plots..		
Determine statistical measures of centre from data displays	<b>Learning intention:</b> To be able to determine statistical measures of centre from data displays		
	<b>Success criteria:</b> SC 1: I can calculate statistical measures of centre from a dot plot.		
	SC 2: I can calculate statistical measures of centre from a stem-and-leaf plot.  SC 3: I can identify outliers in data displays and understand their effects on measures of centre.		

Interpret and describe numerical data displays	<p><b>Learning intention:</b> To be able to interpret and describe numerical data displays</p>		
	<p><b>Success criteria:</b></p> <p>SC 1: I can interpret and choose appropriate data displays.</p>		
	<p>SC 2: I can describe the shape of a distribution.</p>		

Uncorrected proof – sample only

## TOPIC 21: PROBABILITY (SIMULATIONS AND SAMPLE SPACE)

### Content descriptions:

VC2M7P01 identify the sample space for single-stage events; assign probabilities to the possible outcomes and predict relative frequencies for related events

VC2M7P02 conduct repeated chance experiments and run simulations with a large number of trials using digital tools; compare predicted with observed results, explaining the differences and the effect of the sample size on the outcomes

The Victorian Curriculum F-10 content elements are © VCAA

### Pearson Diagnostic quizzes

- Probability (simple outcome spaces)
- Long run probability

TERM 4: Weeks 8–9

Lesson name	Learning intention and success criteria	Differentiating independent practice	Annotations, other resources, teacher sign off
List sample spaces and calculate the probability of single-step events	<b>Learning intention:</b> To be able to list sample spaces and calculate the probability of single-step events		
	<b>Success criteria:</b> SC 1: I can describe chance experiments using the language of probability. SC 2: I can list sample spaces for single-step experiments. SC 3: I can calculate a theoretical probability using a sample space.		
Record outcomes and run trials of chance experiments	<b>Learning intention:</b> To be able to record outcomes and run trials of chance experiments		
	<b>Success criteria:</b> SC 1: I can run trials and record the outcomes of a single-step chance experiment. SC 2: I can run large numbers of trials of a chance experiment.		
Compare theoretical and experimental probability	<b>Learning intention:</b> To be able to compare theoretical and experimental probability		
	<b>Success criteria:</b> SC 1: I can predict the expected number of favourable outcomes for an event. SC 2: I understand the effect of an increased number of trials.		

## References

---

The Victorian Curriculum F-10 content elements are © VCAA, reproduced by permission. The VCAA does not endorse or make any warranties regarding this resource. The Victorian Curriculum F-10 and related content can be accessed directly at the VCAA website.

Uncorrected proof – sample only