

PEARSON
Science
STUDENT BOOK | 3RD EDITION

10



Topic 1 Genetics and models of inheritance

Prior knowledge

The role of the cell nucleus

- 1 The material that is found within the nucleus of eukaryotic cells is known as deoxyribonucleic acid (DNA).
- 2 The role of the nucleus within the cell is to store genetic material and control the cells functions.

Sexual reproduction

- 3
 - a In humans, the male gametes (sex cells) are known as sperm and the female sex cells are eggs.
 - b In flowering plants the male gametes are pollen cells and the female sex cells are the egg cells located in the ovule.
- 4 A benefit of sexual reproduction compared to asexual reproduction is having genetic variation, where organisms have varying characteristics.

Genetics and models of inheritance

- 5 Answers may include any three of: warm-blooded, have hair or fur, have a backbone, have mammary glands.
- 6 Clones should have the same genetic material as the parent plant and each other. This would make them look similar.

1.1 Introduction to chromosomes and DNA

Check your understanding

SC 1: I can recall the role of genetic material in organisms

The purpose of genetic material in humans is to control cell functions, growth and reproduction.

SC 2: I can explain how genetic material is stored within different organisms

DNA is a tightly wound double helix that is arranged into chromosomes, which are found within the nucleus of eukaryotic cells.

SC3: I can label a diagram of a chromosome

A homologous pair of chromosomes:

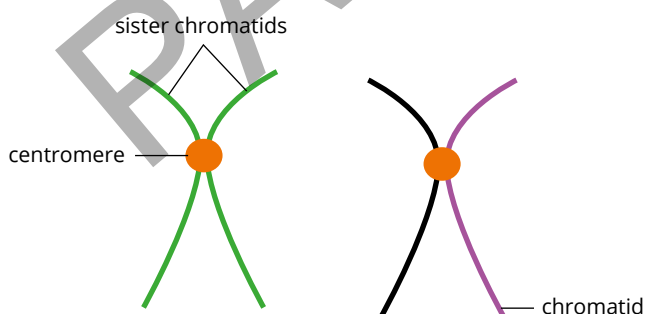

Lesson review

- 1 sugar, phosphate, base
- 2 base, nucleotide, DNA, gene, chromosome
- 3 Rosalind Franklin demonstrated using X-ray crystallography that DNA is a double-helix molecule.
- 4 In eukaryotic cells genetic material is packed into linear chromosomes that can be found within the nucleus, in contrast to a circular chromosome that is freely floating within prokaryotic cells.

- 5 Karyotypes show all the chromosomes within an individual cell as homologous pairs, with the sex chromosomes shown last. If there are two X chromosomes shown then the individual is female, if there is an X and a Y chromosome then the individual is male.

1.2 Extracting DNA

Results

The DNA looks like white, stringy material.

Conclusion

Step 1: The blender breaks down structures of the peas (physical change), such as cell walls.

Step 2: Straining the mixture (physical change) allows the soluble materials and smaller particles to be separated from the larger insoluble materials.

Step 3: The detergent breaks up the chemicals (lipids) that make up the cell membranes (chemical reaction), releasing the DNA.

Step 4: The meat tenderiser contains an enzyme (called papain from the papaya fruit) that breaks down protein (chemical reaction). DNA molecules are wound around proteins and the meat tenderiser reacts to remove those proteins.

Step 6: The alcohol adds an extra layer to the solution. The DNA does not dissolve (physical process) in the alcohol so forms a solid in the alcohol layer. (Other solids in the solution sink to the bottom.)

Step 9: Pulling the threads (physical change) of DNA allows the DNA to be separated from any other remaining material.

Evaluation

- 1 Sample answer: Our experiment was moderately successful. We only produced a small amount of DNA, but it was a pure white colour and we were able to draw out one thread in the last step of the method.
- 2 Sample answer: When we added the alcohol, the layers did not form very well so only a small amount of solid was visible in the alcohol. The test tube needed to be held still (using a clamp) and the alcohol added more slowly.

1.3 Structure of DNA

Results

Bases should be colour-coded with a key (or labelled), and the pairing should be A with T and G with C. Phosphate and sugar molecules should also be labeled similarly to Figure 1.3.4.

Conclusion

- 1 Answers should include reference to other models:
 - having the same base pairs and the same overall structure
 - showing a different order of bases on each strand
 - using different colours to represent the bases and the sugar/phosphate sections.
- 2 Approximately 1 million possible combinations. (There are four different bases – A, T, C and G – in DNA. Therefore, in a strand containing 10 bases, there are $4^{10} = 1\,048\,576$ possible combinations.)
- 3 If the strand were thousands of bases in length, the number of possible combinations would be extremely large.
- 4 The order of the bases on the second strand is determined by complementary pairing (A with T and G with C), which means that only one type of base can pair with each of the bases on the first strand.

Evaluation

Answers may include:

- The model represents the structure of a DNA molecule: the coloured paperclips represent the base pairs, and the strip of paper with colours marked represents the phosphate-deoxyribose backbone.
- This model demonstrates complementary base pairing clearly.
- The model does not show the 3D structure of the DNA double helix well.
- The model is only able to represent a small section of a DNA molecule.

1.4 The role of DNA in heredity

Check your understanding

SC 1: I can describe the structure of a gene and its role in determining alleles in an individual

Alleles are alternative forms of a gene that occupy a specific position on a chromosome.

SC 2: I can explain the functional relationships between DNA, chromosomes, genes and alleles

DNA sequences form genes that can have alternate copies known as alleles that make up an individual's genotype. The genotype of an individual controls the phenotype which are the physical characteristics.

Lesson review

- 1 The phenotype is the physical characteristics that an individual has based on their genotype (alleles).
- 2 Genes are made up of unique sequences of nucleotide bases that make up DNA.
- 3 Examples of phenotypes controlled by alleles that can be found in humans include having brown or blonde hair or having brown or blue eyes.
- 4 Homologous chromosomes contain the same genes, which carry the specific alleles for a characteristic. These alleles can be the same or different on each chromosome depending on the individual's genetic makeup.
- 5 Humans tend to have similar characteristics to each other as 99.9% of their DNA is the same. However, it is the 0.1% of the DNA that is different that can code for different alleles and these alleles produce different phenotypes that contribute to people all looking slightly different.

1.5 Mitosis and meiosis

Check your understanding

SC 1: I can describe the purpose and process of mitosis

interphase (G₁, S, G₂), prophase, metaphase, anaphase, telophase, cytokinesis

SC 2: I can describe the purpose and process of meiosis

Meiosis produces four haploid daughter cells, each genetically unique due to processes like crossing over and independent assortment.

Lesson review

- 1 G₁ for preparation, S for DNA replication, G₂ for preparation
- 2 Cytokinesis is the process that occurs to separate daughter cells.
- 3 The main purpose of mitosis is to produce two genetically identical daughter cells for growth, repair and asexual reproduction.
- 4 **a Meiosis I:** prophase I, metaphase I, anaphase I, telophase I, cytokinesis
Meiosis II: prophase II, metaphase II, anaphase II, telophase II, cytokinesis

- b** The purpose of meiosis in sexually reproducing organisms is to produce gametes with half the chromosome number (n), ensuring the correct number of chromosomes ($2n$) is produced when gametes fuse during fertilisation.
 - c** Genetic variation in meiosis arises from crossing over and independent assortment this ensures that each gamete is unique when contributing genetic material to an individual offspring.
- 5** Mitosis produces two identical diploid daughter cells, whereas meiosis produces four non-identical haploid daughter cells.

1.6 Outcomes of meiosis

Check your understanding

SC 1: I can explain allele variation in gametes as an outcome of meiosis

The chiasma is the point at which two homologous chromosomes exchange genetic material during crossing over.

SC 2: I can define the terms homozygous and heterozygous

Homozygous is when an individual has two of the same alleles in their genotype, whereas heterozygous is when an individual has two different alleles.

SC 3: I can use a Punnett square to predict possible genotypes

	A	A
A	AA	AA
a	Aa	Aa

Worked example: Try yourself

PUNNETT SQUARES

	B	b
b	Bb	bb
b	Bb	bb

$Bb:bb = 1 (50\%):1 (50\%)$

Lesson review

- 1 a** The heterozygous individual would have two different alleles G and g , so would be Gg .
 - b** The homozygous dominant individual would have two of the same alleles, and these are dominant, so written in capitals as GG .
 - c** The homozygous recessive individual would have two of the same alleles, and these are recessive, so written in lower case as gg .
- 2** When constructing a Punnett square, first draw the table, then the parents' genotypes are added to the left and right of the possible offspring boxes. Then one of each of the letters from the corresponding parental gamete boxes go into each possible offspring box.
 - 3** Crossing over occurs between homologous chromosomes during prophase I of meiosis. Sections of one chromosome are swapped with sections of the other chromosome at the chiasma.
 - 4 a** Detached earlobes are a dominant condition as Amara has detached earlobes and she has two dominant alleles present in her genotype.
 - b** Amara's parents could have the genotypes AA and AA , or they could be Aa and Aa , or they could be AA and Aa . Each of her parents must have at least one copy of the dominant A allele. All these combinations could lead to Amara being AA .

- 5 The cross between two homozygous individuals ($AA \times aa$) will yield 100% heterozygous offspring (Aa), while the cross between two heterozygous individuals ($Aa \times Aa$) will yield a genotypic ratio of 1:2:1 (25% AA , 50% Aa , 25% aa).

1.7 Inheritance: Genotypes and phenotypes

Check your understanding

SC 1: I can use dominant and recessive patterns of inheritance to predict the phenotype of an individual based on their genotype

Sidrah and Amirs new baby could have freckles or no freckles. As both Sidrah and Amir are heterozygotes they have a 75% chance of having a baby with freckles and a 25% chance of a baby without freckles. The Punnett square shows the chance of no freckles underlined.

	F	f
F	FF	Ff
f	Ff	<u>ff</u>

SC 2: I can explain sex-linked inheritance

- Sex-linked traits are traits that are found on the X or Y chromosome.
- Males are more likely to be affected by X-linked traits as they only have one copy of the X chromosome and this will result in them being either affected or unaffected; they cannot be a carrier.

SC 3: I can predict the genotypic and phenotypic ratios of offspring in a monohybrid cross

A standard monohybrid cross shows the possible offspring genotypes produced by parents focusing on a single trait. It is presented as a Punnett square.

Lesson review

- A Punnett square is used to determine the chance of specific genotypes being produced by a genetic cross.
- Females with a X-linked recessive trait would have the genotype X^dX^d and males would have X^dY .
- The Punnett square cross between two heterozygous pea plants ($Tt \times Tt$) would look as follows:

	T	t
t	Tt	tT
t	Tt	tt

The phenotypic ratio would be 1:1 (tall:short).

- 4 **a** Females that have Rett syndrome could be $X^R X^R$ or $X^R X^r$ and males are $X^R Y$.

b

	X^r	X^r
X^R	$X^R X^r$	$X^R X^r$
Y	$X^r Y$	$X^r Y$

- c** All of the females in the genetic cross would have Rett syndrome; none of the males would have Rett syndrome.

- 5 a 50:155 which is simplified to 10:31 (red:green)
- b The red beetles would be *bb*, and the green beetles would be a mixture of *Bb* and *BB*, with more having the *Bb* genotype.
- c Based on the offspring produced, it is most likely that the parental genotypes would be *Bb* and *Bb*.

1.8 Modelling genetic variation

Results

- 1 Sample table:

Trait	Parent 1		Parent 2	
	Genotype	Phenotype	Genotype	Phenotype
1	<i>Tt</i>	brown eyes	<i>Tt</i>	brown eyes
2	<i>Ff</i>	freckles	<i>Ff</i>	freckles
3	<i>Bb</i>	bent little finger	<i>Bb</i>	bent little finger
4	<i>Ll</i>	broad lips	<i>Ll</i>	broad lips
5	<i>Dd</i>	dimples	<i>Dd</i>	dimples

- 3 Sample table:

Trait	Offspring 1		Offspring 2		Offspring 3		Offspring 4	
	Genotype	Phenotype	Genotype	Phenotype	Genotype	Phenotype	Genotype	Phenotype
1	<i>TT</i>	brown eyes	<i>Tt</i>	brown eyes	<i>Tt</i>	brown eyes	<i>tt</i>	blue eyes
2	<i>Ff</i>	freckles	<i>Ff</i>	freckles	<i>ff</i>	no freckles	<i>FF</i>	freckles
3	<i>bb</i>	straight little finger	<i>BB</i>	bent little finger	<i>Bb</i>	bent little finger	<i>Bb</i>	bent little finger
4	<i>LL</i>	broad lips	<i>ll</i>	thin lips	<i>Ll</i>	broad lips	<i>Ll</i>	broad lips
5	<i>DD</i>	dimples	<i>Dd</i>	dimples	<i>dd</i>	no dimples	<i>Dd</i>	dimples

Conclusion

- 1 Rolling the die to select alleles by chance represents what happens during meiosis. As chromatids are segregated (separated) during meiosis, the genetic material from the parent's diploid set of chromosomes is randomly split to produce the genetic material in each of the haploid gametes. The parent has two alleles for each gene but only one allele goes into each gamete, which is similar to what happened when the die was rolled to select one of the two alleles from the set of cards. After rolling the die 10 times, alleles were paired up for each trait from each of the two parents. This process mimics the way that the two haploid sets of chromosomes in two gametes join into a zygote during the process of fertilisation.
- 2 With five genes (representing five traits), the number of possible genotypes is:
 2 (first gene) \times 2 (second gene) \times 2 (third gene) \times 2 (fourth gene) \times 2 (fifth gene)
 This can be written as:
 $2^5 = 32$ possibilities
 With 10 genes (representing 10 traits), the number of possible genotypes is much greater:
 $2^{10} = 1024$ possibilities

- 3** The genotypes of offspring are independent of each other. The probability of each genotype occurring in each cross between two individuals is independent of (not affected by) other crosses between those individuals. Starting with two full sets of alleles before rolling the die means that each gamete has an equal chance of 'inheriting' each of the two alleles for a gene from the parent, independent of any earlier crosses that have taken place.

Evaluation

- 1 a** For the trait of dimples, let D represent the dominant allele (dimples) and d represent the recessive allele (no dimples).

	D	d
D	DD	Dd
d	Dd	dd

- b** Offspring with the genotype DD or Dd will have dimples. Offspring with the genotype dd will not have dimples.
- c** 3:1 dominant:recessive, or 3:1 dimples:no dimples
- d** A yes or no answer is sufficient.
- 2** Answers should include:
The modelling process and the process of meiosis are both random.
Punnett squares are used to determine the possible phenotypes and genotypes of a genetic cross and their expected ratios. In reality, a genetic cross between two heterozygous individuals may not produce a 3:1 ratio of dominant:recessive phenotypes in the offspring.
While the modelling process used in the practical investigation is random, the process of determining phenotypes and genotypes using a Punnett square is not, so it is likely that different phenotypic and genotypic ratios will be observed in the Results section and in the Punnett square in part a.

1.9 Pedigree diagrams

Check your understanding

SC 1: I can identify the pattern of inheritance for dominant and recessive traits using a pedigree diagram

- a** shaded square
- b** shaded circle
- c** unshaded square
- d** unshaded circle

SC 2: I can identify the pattern of inheritance for sex-linked traits using a pedigree diagram

All females affected by an X-linked recessive trait must have a father who is also affected by the recessive trait.

SC 3: I can develop a pedigree diagram to model inheritance of genes through families

Mating lines are shown by a horizontal line connecting two individuals.

Lesson review

- 1** A pedigree diagram is a chart that shows the occurrence and appearance of phenotypes of a particular gene or organism and its ancestors across multiple generations.

- A pedigree diagram can be used to identify dominant and recessive traits by analysing the patterns of inheritance across generations. Dominant traits typically appear in every generation, while recessive traits may skip generations and appear only when two carriers or individuals with recessive traits reproduce.
- Start by looking for a trait that appears more frequently in males and is passed from carrier mothers to their sons, with affected males not passing the trait to their sons but potentially passing it to their daughters.
- Students should draw the following:

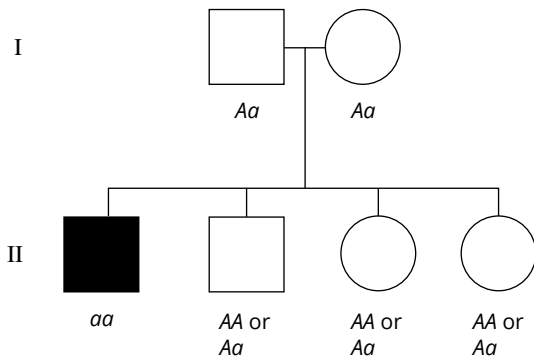

- Based on the pedigree it could be concluded that the mode of inheritance is autosomal dominant. It cannot be X-linked dominant as the affected male in the second generation (II4) has both affected (III2) and unaffected daughters (III1) in the third generation.

1.10 First Nations kinship laws

Check your understanding

SC 1: I can describe kinship laws of First Nations Australians moieties, totems, skin groups

SC 2: I can describe the potential outcomes of inheritance patterns of genetic defects

If both of an individual's parents are heterozygous carriers of a genetic disorder, then they can pass the genetic disorder onto their children if the children get two copies of the affected alleles.

SC 3: I can describe the genetic benefits of imposing certain rules through marriage restrictions

Siblings, parents and grandparents are most likely to have similar genetic material, so the prohibition of marriage between these family members reduces the chance of genetic conditions being passed onto offspring.

Lesson review

- A genetic defect is an abnormality in the DNA that can cause diseases or disorders.
- Answers may include any two of:
 - Autosomal dominant conditions: achondroplastic dwarfism, Marfan syndrome or Huntington's disease
 - Autosomal recessive conditions: cystic fibrosis, sickle cell anaemia (a blood disorder), Tay-Sachs disease or phenylketonuria
 - X-linked dominant conditions: rickets
 - X-linked recessive conditions: colour-blindness, haemophilia and some forms of muscular dystrophy.
- Kinship laws are significant in First Nations Australian communities because they define social structure, determine roles and responsibilities, and ensure the maintenance of cultural traditions and social harmony.
- If neither parent has a genetic disorder but are both carriers, then they would have a 25% chance of having a child with a genetic disorder. A Punnett square with two heterozygotes would show this 3:1 ratio of unaffected to affected.

1.11 Changes to DNA

Check your understanding

SC 1: I can describe environmental conditions or other factors that can cause changes in DNA or chromosomes

A mutagen is an agent that has the potential to cause a change in DNA code.

SC 2: I can describe different types of changes in DNA or chromosomes

insertions, substitutions, deletions

SC 3: I can explain potential changes in the body caused by changes in DNA or chromosomes

Answers may include one of each of the following:

DNA point mutation: Huntington's disease, sickle cell anaemia or cystic fibrosis.

Chromosomal mutation: Down syndrome or Edwards syndrome.

Lesson review

- 1 UV radiation, carcinogens (such as chemicals from cigarettes), plastics (BPA and phthalates)
- 2 UV radiation can interfere with the bonding between the nucleotides in DNA, which means that cells cannot carry out their regular functions.
- 3 The change in DNA code shown would be an example of a point mutation involving a deletion of nucleotide bases.
- 4 A point mutation may have a minor effect, potentially altering a single part of a protein, while a chromosomal deletion can remove multiple genes, leading to more severe consequences such as developmental disorders or diseases.
- 5 Genetic counsellors assist people who have or who carry a genetic condition by providing education about the effects of inherited disorders and the chance of passing these on to offspring.

1.12 Genetics and disease

Plan

Part A: The impact of mutations on human health

Answers may include:

Condition	Genetic mutation	Impact	Inheritance/contributing factors
Cancer	mutations in genes like <i>TP53</i> or <i>BRCA1/2</i> disrupt regulation of cell division and DNA repair	leads to uncontrolled cell division and tumour formation	can be caused by environmental exposures or inherited mutations
Haemochromatosis	mutations like <i>C282Y</i> and <i>H63D</i> in the <i>HFE</i> gene affect iron regulation	causes excessive iron absorption and accumulation in tissues and organs	autosomal recessive; more common in certain populations; possibly spread via viking migration
Sickle cell anaemia	mutation in both copies of the <i>HBB</i> gene causes substitution of glutamic acid with valine	alters red blood cell shape to a sickle form, impairing oxygen transport	autosomal codominant; prevalent in areas with historic malaria—sickle shape provides some malaria resistance
Cystic fibrosis	mutations like <i>Delta F508</i> in the <i>CFTR</i> gene affect chloride ion transport	causes thick, sticky mucus buildup, especially in the lungs and digestive system	autosomal recessive inheritance

Part B: The role of technology in genetic screening and treatment

Answers may include:

Condition	Diagnostic technologies	Treatment technologies
Cancer	<ul style="list-style-type: none"> DNA sequencing techniques (e.g. NGS) to identify cancer-related mutations molecular tools like PCR to detect genetic alterations in tumour cells 	<ul style="list-style-type: none"> targeted therapies (e.g. monoclonal antibodies, small molecule inhibitors) immunotherapies enhanced through genetic engineering
Haemochromatosis	<ul style="list-style-type: none"> genetic testing (e.g. PCR or DNA sequencing) to detect <i>HFE</i> gene mutations MRI or CT scans to assess iron accumulation 	<ul style="list-style-type: none"> regular blood donations to reduce iron levels genetic counselling to understand and manage hereditary risk
Sickle cell anaemia	<ul style="list-style-type: none"> genetic testing (PCR/DNA sequencing) to detect <i>HBB</i> mutations prenatal testing to identify carriers 	<ul style="list-style-type: none"> gene therapies (e.g. CRISPR) to correct <i>HBB</i> mutations symptom-targeting medications
Cystic fibrosis	<ul style="list-style-type: none"> genetic testing (PCR/DNA sequencing) to detect <i>CFTR</i> mutations sweat test to measure chloride levels 	<ul style="list-style-type: none"> <i>CFTR</i> modulators that improve defective protein function emerging gene therapies to correct <i>CFTR</i> mutations

Part C: Panel discussion of benefits and risks of gene therapy

Strong answers will:

- clearly state positions for or against gene therapy
- reference specific conditions and supporting evidence
- respectfully address opposing arguments.

Design

Answers will vary. It is important to ensure that scientific language is used throughout the design.

Conduct

Answers will vary. Students should ensure that their presentation is kept factual without any bias.

Evaluate

- 1 Answers may include specific benefits and risks of gene therapy, backed up by information from their research. Students may wonder about their genetic makeup and risk factors or reflect on their family health history, both past and present. They could also consider lifestyle changes to prevent and reduce the risk of developing any diseases later in life. Additionally, they may be interested in learning more about certain genetic conditions or populations in which these conditions are more prevalent.
- 2 Answers may include skills such as research, critical thinking, analysis and communication.

Topic review

Remember

- 1 Sample diagram:

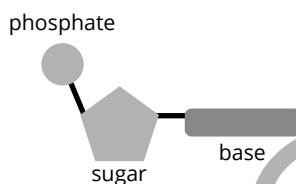

- 2 adenine (A), thymine (T), cytosine (C), guanine (G)

Complementary base pairs: adenine (A) pairs with thymine (T), cytosine (C) pairs with guanine (G)

- 3 Phenotypes are a physical expression of a genotype.
- 4 The buffer solution helps to break down cell membranes and proteins, allowing the DNA to be released from the cells.

Understand

- 5 A gamete is a sex cell that contains half of the genetic material as the parent. In humans, gametes have 23 chromosomes, which is the haploid number. When two gametes fuse and form a zygote it contains 46 chromosomes.
- 6 Kinship laws that restrict marriage within certain groups can reduce the likelihood of inheriting genetic defects by preventing the union of closely related individuals who may carry the same recessive alleles.

Apply

7 a Alleles are different forms of a gene. For eye colour, one allele might code for blue eyes and another for brown eyes. The combination of alleles inherited from each parent determines the eye colour.

b

	<i>B</i>	<i>b</i>
<i>B</i>	<i>BB</i>	<i>Bb</i>
<i>b</i>	<i>Bb</i>	<i>bb</i>

c The genotypic ratio is 1:2:1 (*BB*:*Bb*:*bb*) and the phenotypic ratio is 3:1 (Brown:blue)

d There is a 25% chance that their child will have blue eyes.

8 Meiosis increases genetic variation through processes like crossing over and independent assortment, which shuffle genes and create unique combinations in gametes, contributing to variation in offspring.

9 Three genetic crosses that only produce one phenotype in offspring include: a cross between two homozygous dominant parents $AA \times AA = \text{all } AA$, a cross between two homozygous recessive parents $aa \times aa = \text{all } aa$ and a cross between two a homozygous dominant parent and a homozygous recessive parent $AA \times aa = \text{all } Aa$.

10 Dominant alleles mask the effect of recessive alleles when both are present in an individual. A trait coded by a dominant allele will be expressed even if only one copy is present, while a trait coded by a recessive allele will only be expressed if two copies are present.

Analyse

11 a An autosome is a non-sex chromosome. Humans have 44 autosomes.

b

	<i>r</i>	<i>r</i>
<i>R</i>	<i>Rr</i>	<i>Rr</i>
<i>r</i>	<i>rr</i>	<i>rr</i>

There is a 50% chance that the child of the parents will have PCD.

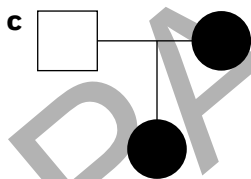

d Potential genotypes of the father's parents include: *Rr* and *Rr* or *rr* and *rr*, as the father is not affected.

12 a Mitosis results in two identical daughter cells with the same chromosome number as the parent cell, while meiosis results in four genetically diverse gametes with half the chromosome number of the parent cell.

b A deletion mutation removes a segment of DNA, potentially leading to a loss of gene function, while a duplication mutation adds an extra segment. Both can disrupt normal development and function, but the specific effects depend on the genes or chromosomes involved.

13 The mode of inheritance shown in the pedigree is autosomal recessive. As individuals 6 and 7 do not have the trait themselves but have a child (individual 9) who is affected, they must both be heterozygous carriers of the trait.

Extension: Research task

- 14** Students would present ideas listing the types of genetic defects that NIPT can detect, including the sex of an individual and chromosomal anomalies. They would then look at arguments for and against NIPT, including potential examples such as parents understanding potential defects that may affect their child and determining if they were to retain or abort the pregnancy, interference in the natural order of life, the cost of the testing and access for all people to this type of medical knowledge.

PAGE PROOFS